

FREE GLOBAL STANDARDS DIRECTORY PULLOUT



THE COMPLEXITY OF PRINTER CARTRIDGE COMPONENTS PAGE 7



LOCKED OUT DURING THE LOCKDOWN PAGE 13

TRUSTING CHINESE SUPPLIERS TO MAINTAIN QUALITY PAGE 41



ImaginaWorld

in Print in 5 Languages

CONTINUING TO SET HIGH INDUSTRY STANDARDS

PAGE 30

— Chris Nichols, Static Control's Product Development Manager



Issue 113 (US\$10.00)

ISSN 2050 6449



9 772050 644909

Watch inTouch TV News Daily Online



Partnering with Incorporating and magazines

www.RTMworld.com

Special Edition STANDARDS & TESTING

MORE ADV MORE OPP JOIN RT'S WORL

*I've got
perfect 20/20
vision!*

**If you have 20/20 vision
you can see clearly ahead.*



To get event updates, please follow us on social media:



recyclingtimes



Recycling_Times



RT Media Co., Ltd.



irecyclingtimes

To visit, please contact: Kim Tan

Kim.Tan@RTMworld.com

+86-756-3959285

To exhibit, please contact: Victoria Zhao

Victoria.Zhao@RTMworld.com

+86-756-3919263

For media cooperation, please

Amber.Guan@RTMworld.com

+86-756-3959286

**RT reserves the right to amend dates and locations*

VENTURES OPPORTUNITIES AND TOUR IN 2020

RT Expos in 2020

Date	Destination	Event
January 9 January 11-12	Pakistan	RT Imaging VIP Expo—Asia 2020 RT EOS Imaging Show 2020
May 11 / 13 / 15 <i>*Postponed to 2021</i>	UK Netherlands France	RT Imaging VIP Expos—Europe 2020
June 3-5 <i>*Postponed to 2021</i>	Russia	Business-Inform 2020
July 3 / 7 / 10 <i>*Postponed to 2021</i>	Argentina Brazil Peru	RT Imaging VIP Expos—Americas 2020
September 17-19	Shanghai, China	China Stationery Fair —RemaxWorld Shanghai 2020
October 15-17	Zhuhai, China	RemaxWorld Expo 2020 iPrint Expo 2020
November 16 / 19 / 23	Ethiopia Tunisia Nigeria	RT Imaging VIP Expos—Africa 2020

RT VIP Expos are big buyer, best supplier events.

contact: Amber Guan

RT

www.RTMworld.com

Quality Wins the Future

CET is committed to delivering the quality you need and you expect



Designs and engineers products to meet the highest quality standards



Third party inspection and testing laboratory authorized by the state, nearly 1000 test printers and copiers

High quality manufacturing based on highly-skilled teams



State-of-the-art equipment create high quality products



IMAGING WORLD

No. 113 | 2020

05 | EDITORIAL

Standards, Testing and Integrity



20 | REGIONAL STANDARDS

Printing Standards in the Arab World



24 | NEW STANDARDS FOR EUROPE

Setting New Standards in Europe



28 | IN MY VIEW

Which standards (quality/ management/ testing/ environmental) do you utilize in your business?

46 | QUOCIRCA REPORT

COVID-19: Accelerating Print Industry Transformation

30 | FRONT COVER STORY

Static Control Continues to Set High Industry Standards



Cover: Chris Nichols, Static Control's Product Development Manager. Photo courtesy: Static Control



The first part of 2020 may have seen the world in lockdown, but it was not lockout for RT ImagingWorld's David Gibbons (right) who was able to talk to industry giants like Print-Rite's Arnald Ho (left) and RT's regional partners in Argentina, Europe, Africa, USA and India about the trends facing the industry this year. The inTouch TV News and RT Market Insights are available at <www.rtmworld.com>

FEATURES

6 Testing Cartridge Components and Meeting Standards

—Graham Galliford

Matching components in any cartridge is important for optimal print and operational performance.

12 Coronavirus Lockdown ... and Now a Printer Lockdown

—Michael Gell

A firmware update can lock the installed printer cartridge, as well as subsequent third-party replacements stopping it from working the moment the update takes effect.

40 Trust—Looking for Products in China that Consistently Maintain Quality

—Teddy Chen

A strong reputation for quality can be an important differentiator in markets that are highly competitive.

50 | END OF THE DAY WITH RAY

Meeting Standards Means Staying Relevant



51 | LATAM LETTERS

Can Latin America Manufacture its Own NBCs—and be Profitable?



52 | Into India

India—Price or Standards? Now That is the Question



53 | INTERNET OF PRINTING

Printer Supplies Opportunities Post COVID-19



56 | THE LISTS

Berto's last laugh on standards in the factory

39 | 5 QUESTIONS

Using Standards to Market Products

Kim Lee



Recycling Times informs, educates, and nurtures the global printer consumables industry innovatively through an integrated broadcast, print, digital and social media strategy. As such, we honor and respect the intellectual property of all businesses and individuals. Consequently, we take a zero tolerance position to the manufacture, distribution and sale of patent infringing and counterfeit printer cartridges and components. We continue to strive to avoid promoting such in our advertisements, articles and editorial content. All rights reserved. © June 2020 by Recycling Times Media Corporation. No content is to be copied or republished without official written consent. The views of the writers and columnists in this magazine do not necessarily reflect the official position and views of Recycling Times Media Corporation. They are published to encourage thinking and discussion among and between the Aftermarket and OEM imaging sectors. The content provided for publication by Recycling Times Media is the sole responsibility of each respective contributor, being their own proprietary work. Such content is not subject to fact-checking, but is edited for its reasonableness. Recycling Times Media may correct or enhance previously published content at its sole discretion. Readers are further advised to apply due diligence when doing business with any advertiser or company mentioned in this publication.

UNLIMITED INNOVATION: KILIDER NEW PATENT ISSUED

KILIDER
凯利德

Patent-free Toner Cartridge KLD-IMC3500/MPC3503
Invention Patent No.: 201911189749.4

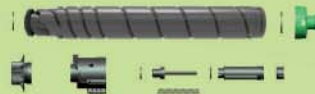

KLD-IMC3500/MPC3503



Used For KLD-IMC3500/MPC3503

Compatible With: For RICOH IMC3500/IMC3000
Invention Patent No.: 201911189749.4

KLD-MX310
CN Invention Patent No.: 201910495312.7
US Invention Patent No.: 16451011
EU Invention Patent No.: EP19182322.8

KLD-TN-328
CN Invention Patent No.: 201911341906.9

KLD-MP C8002/C8003
CN Invention Patent No.: 201910204654.9

KLD-C3371
CN Invention Patent No.: 201910203468.3

KLD-SP C352/C360/361
CN Invention Patent No.: 201910204654.9

KLD-NPG-73/GPR-57/C-EXV53
KLD-NPG-71/GPR-55/C-EXV51
CN Invention Patent No.: 2019104118810.1
US Invention Patent No.: US16/442587
EU Invention Patent No.: EP19180456.6

KLD-TK1200/1150/1160/1170
CN Invention Patent No.: 201811374841.3

KLD-OKI 310
CN Invention Patent No.: 201910895742.8
US Invention Patent No.: 16595517

If you want to know more about us, welcome to visit our website:
www.kilider.com



+86-769-81154355 / 81154366

FAX: +86-769-83116077

EMAIL: sales6@kilider.com (John) info@kilider.com (Nate) sales9@kilider.com (Hebe)
sales3@kilider.com (Catherine) sales8@kilider.com (Orange Chen)

ADDRESS: Huangyuan Area, Shangrao Economic and Technological
Development Zone, Shangrao City, Jiangxi Province, China





Tricia Judge

This publication addresses the complicated but so important issue of standards and testing. The amazing compilation of articles from around the globe demonstrate how multi-faceted standards and testing are. However, the issue is actually pretty simple: we are talking about quality. Provable, repeatable quality.

Twenty years after the adoption of STMC by Int'l ITC and industry members, I am still often asked what type of standards are set by STMC. It doesn't.

STMC is all about testing your cartridges so that a manufacturer, distributor and even customers can determine the cartridges' performance. There is no pass/fail.

A standard set for a cartridge requires that it meets a prescribed level of performance, or it "fails." This line is often blurred, so I understand why it causes confusion.

There is one thing that both have in common. Neither testing nor standards can be modified. "We use our own version of STMC," I've been told. No. You don't. It's an established and prescribed standard or test, and must be used as written, vetted and passed by consensus. Any "modified" or "better" version is NOT a version at all.

STMC is a testing protocol that employs several ASTM, ISTA and ANSI standards to make up a process that allows everyone to easily test a cartridge for page yield, image density and background. These standards were painstakingly designed to be easily usable and repeatable by anyone from OEMs down to actual consumers.

Standards, like ISO 9000, require that a company use certain processes in manufacturing. It encourages consistency (but not necessarily excellence) in product quality.

Standard and testing certifications are also subject to counterfeiting and misrepresentation. Certifications have been fraudulently displayed on products and marketing materials. All of the certifying organizations maintain criteria for checking authenticity on their websites. Check them. Every time. Before you buy.

In the final analysis, the strongest test or standard of a producer is its integrity.

Tricia
Senior Consulting Editor



Publishers

David Gibbons Tony Lee

Editorial

USA

Tricia Judge (Senior Consulting Editor)
<Tricia@RTMworld.com>

China

Maggie Wang <Maggie.Wang@RTMworld.com>
Tequila Yan Amber Guan

Design

Miuling Peng

Partners

Latin America

Gustavo <Molinatti.gmolinatti@guiadelreciclador.com>

Europe

Mark Dawson <Mark.Dawson@RTMworld.com>

Africa

Stuart Lacey <stuart@delace.co.za>

India

Dhruv Mahajan <Dhruv.Mahajan@RTMworld.com>

Russia

Business Inform
Stanislav <Malinskiy.malinskiy_stas@mail.ru>

Egypt

Arab Print Media
Walid <Qorish.walid@arabprintmedia.com>

Offices

Australia

Sabrina Lo <Sabrina.Lo@RTMworld.com>

Korea

James Hwang <jdhwang@hotmail.com>

Japan

Iemori Kanetoyo <kanetoyo@sunwise2001.com>

China-Head Office

Office 2302, Building 2, V12 Creative Park, No. 32 Nanwan North Road, Zhuhai, China

Tel: +86 (0)756 3220716

Subscriptions

Maggie Wang <Maggie.Wang@RTMworld.com>

Advertising

Victoria Zhao <Victoria.Zhao@RTMworld.com>

Email: editor@RTMworld.com
Website: www.RTMworld.com



WE CAN HELP YOU TO
COMMUNICATE
WITH THE WORLD



ID: recyclingtimes
20,000+ followers



ID: Recycling_Times
18,000+ followers



ID: RT Media Co., Ltd.
8,000+ followers



ID: intouchnews
67,000+ video views



ID: Recycling Times Media
22,000+ video views



Chinese Toutiao App
76,000+ annual page views



WeChat ID: i3dpworld
57,000+ followers



WeChat ID: irecyclingtimes
17,000+ followers



www.RTMworld.com

Testing Cartridge Components

and Meeting

Standards

 *Graham Galliford*



Graham J. Galliford is a world-renowned consultant, researcher, writer and speaker for the global imaging industry. His work has encompassed technologies in a variety of printing components and products but has worked primarily in the field of toner-based printing technology since 1974. He can be contacted at [<graham@gallifordconsulting.com>](mailto:graham@gallifordconsulting.com)



The OEMs designed print engine determines the characteristics of the print cartridge. Printer cartridges are complex and comprise many different structural and print process functional components. The many components in the cartridge use a wide variety of materials including plastics, adhesives, foams, metals, dyes, pigments, waxes, dyes, organic and inorganic chemicals, glass fiber, elastomer and felt. Each component has a specific function, dimensions and material properties determined by the print process. The operational parameters of each print engine vary significantly as do the components. Each component of each cartridge has a specification set by the manufacturer including tolerances depending on the specification, tolerances and performance of upstream and downstream components. Matching components in any cartridge is important for optimal print and operational performance.

Standards

There are no general or specific standards other than environmental and safety standards for cartridge components. The de facto standard for any cartridge performance is that of the OEM cartridge. The specifications of OEM components tend to drive third party cartridge component specifications. So, third party cartridge components closely approximate the specification of OEM components, but no third-party component

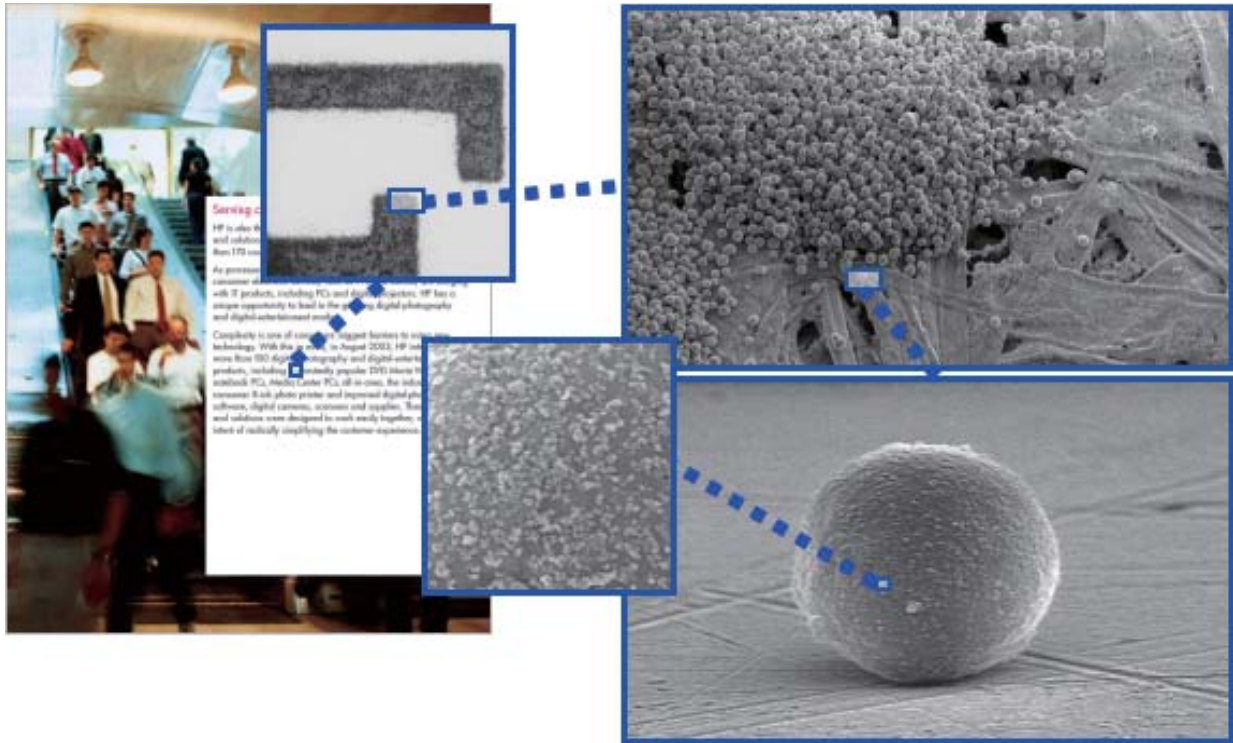

exactly replicates the OEM because they use entirely or partially materials, manufacturing equipment, processes and conditions different, but similar, to the OEM. Each third-party component is slightly different from that of the OEM means that in the aftermarket, whether remanufactured or new built, it is crucial that components used are matched to achieve OEM cartridge and print engine performance.

Establishing Cartridge Performance Standard

Measurement of the performance of a cartridge in a print engine is well defined and practiced. The International Organization for Standardization and the International

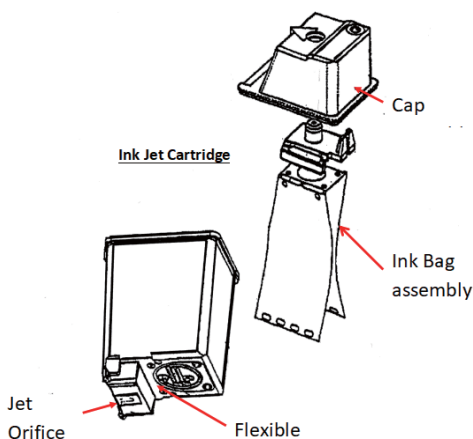

Electrotechnical Commission (ISO/IEC) and the American Society for Testing and Materials International (ASTM) as well as the International Safe Transit Association (ISTA), American National Standards Institute (ANSI) and the International Committee for Information Technology Standards (INCITS) all have standards or input to standards regarding the performance of print cartridges. Particularly ISO/IEC and

Human visual inspection can keep up with drum processing speed, and the sensitivity of human vision is good but is subjective and can be inconsistent.

ASTM provide controlled methods for testing overall performance of monochrome and color cartridges against the de facto OEM performance standard.

As there are no specific standards for individual components, manufacturers develop their own test protocols, procedures and specifications for whatever component they are manufacturing including physical, chemical, electrical and magnetic properties.

Component Testing

Establishing specifications for parts and components for third party manufacturers is complicated. Manufacturers of an incomplete range of components have to try to make their products compatible with the widest range of

other components available on the market. This is a major challenge. The parts that are functional in the printing process in toner cartridges are the photoconductor, primary charge roller (PCR), development roller (DR), cleaning blade (CB), toner, doctor blade (DB) and chip.

Testing each component is important and there are common test procedures for each of the important parameters for each component

in research, development and design. Once development is complete and components are to be manufactured, quality is determined by input raw material quality control and manufacturing process and condition control.

The objective is to build quality into a product by controlling input and verifying with optimized and minimized output testing. Statistical process control can readily help to achieve the goal of efficiently ensuring product quality.

Testing in Development and Manufacture

• Photoconductor

Defects in photoreceptors are among the most significant sources of print defects in cartridges. In photoreceptor production, it is critical that defects be identified and that photoreceptors with unacceptable defects not be shipped to customers. In development testing, the important electrical properties measured are charge acceptance,

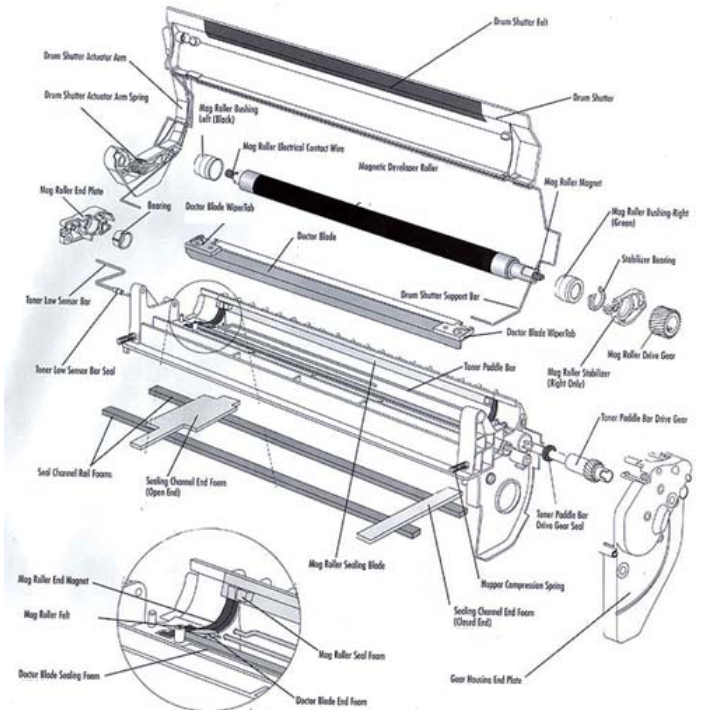
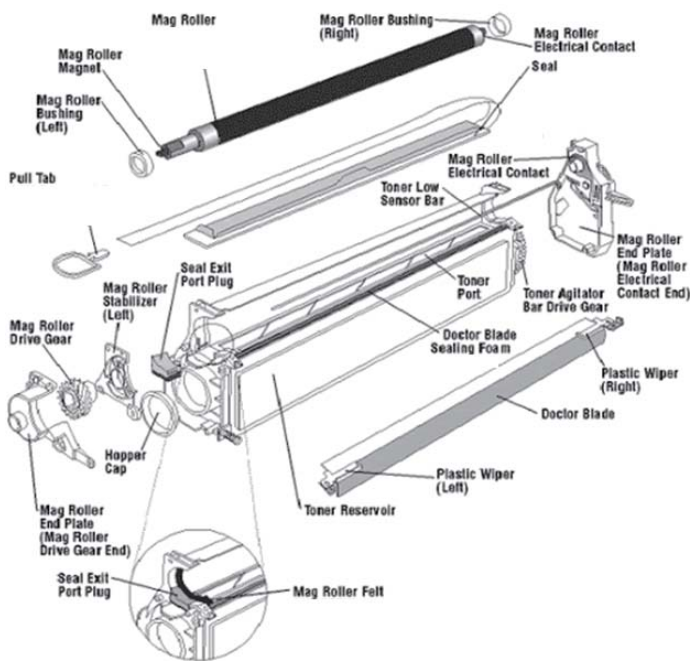

capacitance, dielectric thickness, dark decay, photosensitivity (photo induced discharge characteristics (PIDC)) and spectral sensitivity, charge mobility, fatigue charge acceptance—that decrease with print cycling (cycle down) or increase in residual charge with print cycling (cycle up), coating uniformity, defects and wear mapping, coating hardness/toughness and layer adhesion. Dimensional accuracy of cores also affect performance and subject to run-out limits. These characteristics are determined by coating formulation, input raw material quality and manufacturing process control. Developmental testing includes testing in differing environmental conditions to ensure performance up to the limits defined by the OEM. Final development testing is application testing in a cartridge with the manufacturers preferred other components.

Manufacturing process control for photoconductors includes testing coating viscosities, coating material temperature, dip coating speed and drying temperature and duration. In production, the most commonly used method for examining photoreceptors for defects is visual inspection. Human visual inspection can keep up with drum processing speed, and the sensitivity of human vision is good but is subjective and can be inconsistent. Instrumentation using electrostatic mapping

is used by some to batch check production. Process and input material control are key to efficient in specification production.

• Toners

Just as the case in photoconductors, manufactured quality is determined by input raw material quality control and manufacturing process control. The characteristics that determine performance

Ink chemistry and formulations not only dictate the quality of the printed image, but they also determine the drop ejection characteristics and the reliability of the printing system.

include specific charge (Q/M), particle size distribution (PSD), melt flow index (MFI), flowability and glass transition temperature (T_g). Toners are micro-fine powders of ground compounds of polymer, pigments, waxes and charge control agents (CCA) with nano-size extra-particulate additives typically fumed silica and titanium dioxide.

Manufacturing process and its control depends on the type of toner being produced. The two major categories by manufacturing concept are conventional or mechanical toner (MPT) and chemical or chemically prepared toner (CPT). There are several different types of CPT and each process has its differing

manufacturing steps and control parameters. Output product control of any toner is determined by the specification and quality of the input raw materials, controlling the production conditions of each process step and using statistical process control ensures that the product is made within specification and minimizes testing need.

In development, testing conducted includes bench tests and operational tests under the full range of environmental conditions. Developmental testing includes the use of a differential scanning calorimeter, capillary rheometer and melt flow indexer to evaluate melt performance and determine T_g. Testing with a particle size analyzer determines mean particle size

(d₅₀) and particle size distribution including d₅ and d₉₅. Optical and scanning electron micrography is used to evaluate toner particle surface morphology, extra particulate dispersion and particle shape. Tribo charge testing determines specific charge (Q/M) and charge distribution and a combination of six tests to determine the toner flowability index. Functional testing in a test cartridge is the final development testing using the manufacturers preferred other components.

Manufacturing testing is minimized as with other components by ensuring that the input materials are within specification and that the step by step processing conditions

ZHONO
Imaging a Better World

ONE-STOP SHOPPING

Compatible Chip for:

Xerox, HP, Kyocera, Ricoh, Sharp, Toshiba,
Konica Minolta, Canon Series



Chips for more than 8000 main stream laser printers and digital copiers

● The picture is for reference only, Zhono reserve the rights of final interpretation. ● All brand names and trademarks appearing for reference only.



RemaxWorld Expo 2020

Booth No. 2315



sales@zhono.com

www.zhono.com



are within control limits. While toner composition controls many parts of the specification of a toner, process condition controls tend to control physical attributes. The major property that has a significant role in governing quality is PSD. This is one characteristic that is commonly tested either in-line in production or periodically off-line in production. If processing conditions are within the control parameters other than a situation where manufacturing equipment deteriorates, quality can be verified by checking this one parameter.

• Inks

The most critical component of inkjet printing is the ink. Ink chemistry and formulations not only dictate the quality of the printed image, but they also determine the drop ejection characteristics and the reliability of the printing system.

Critical metrics which are controlled by ink formulation and raw materials include viscosity, surface tension, PH, jetting stability/reliability, kogation resistance, optical density and color value, resolution, inter-color bleeding, color uniformity and wet fastness. There is additional impact of the materials on particle size, particle size distribution and dissolved gas content. Manufacturing processes are also key to these parameters.

The quality of ink production is ensured and testing is minimized by controlling materials as well as the manufacturing process. Batch testing of viscosity, pH and filtration check are important QC tests that are conducted on inks by manufacturers.

• Chips

Component quality and manufacturing process control are key to the quality of

the finished product. Batch testing of chips with specialized test rigs are used for both development and manufacturing quality testing.

• PCR, DR

The performance of PCRs and DRs depends critically on dielectric relaxation of the semi-insulating dielectric layers in these devices. In the case of mono-component magnetic toner DRs, there is the additional need for magnetic testing. In the semi-insulating dielectric, the progress of dielectric relaxation is controlled by the charge injection from bias and the charge mobility, rather than by the bulk resistance. These characteristics are determined not only by the materials used but also the

As a practical matter, component manufacturers individually can only control their piece of the whole environmental and health compliance.

processing conditions in manufacture. Of equal importance are dimensional accuracy of the part. Input testing of the raw materials for coatings and physical measurement of sleeves, tubing, shafts and magnetic materials is the foundation of quality production. In development as well as commercial manufacture, measurement of dielectric properties is conducted to ensure quality. The specialized equipment is to map electrical properties of PCRs and DRs as well as to verify properties as well as to identify any defects.

• Cleaning Blades, Sealing Blades, Recovery Blades, Toner Adder Rollers, Drum Shutters, Seals, Bushes, Felts, Gears and Bearings

All of these products are important components and are controlled by formulation/material choices, and manufactured dimension control. Input raw material control and dimensional measurement are the testing actions that determine quality. Plastic parts that are injection molded, vacuum formed or machined are batch tested after production in controlled conditions.

• Environmental and Safety Requirements

All cartridge components, but in particular cartridge parts such as casings and structural parts, are subject to requirements including physical needs of dimension and structural strength. Adding all components in combination when assembled as a cartridge

must comply with environmental and health regulations. In global context such regulations vary regionally and nationally. This includes chemical content restrictions on such materials as brominated flame retardants, heavy metals and volatile organic

compounds. The whole cartridge is subject to these requirements if used, sold and/or shipped as are individual components not included in a cartridge if used and shipped. Compliance with such regulation is ensured by input raw material control. As a practical matter, component manufacturers individually can only control their piece of the whole environmental and health compliance.

In summary, manufacturers cannot “test quality into their products.” The critical way to ensure quality and ease the burden of quality control testing is to use quality input materials that are able to be reliably sourced in specification and tightly control manufacturing processes and conditions. ■



Michael Gell specializes in designing and building enterprises that can operate in ways that are aligned with the Earth, its ecosystems and inhabitants. His career began with British Gas R&D in the late 1970's. Following a decade of research into industrial energy efficiency and low-energy houses, his focus broadened to advanced electronics with IBM and MOD. He established BT's research center on quantum electronics in 1986. In 1990 he set up the corporation's research center on digital technologies which spearheaded the transformation of the telephone giant into the internet age. Michael established an independent energy and environmental business in 1995 and this has evolved to Greenlick. Please contact <mgell@greenlick.co.uk>.

Coronavirus Lockdown ... and Now a Printer Lockdown

 *Michael Gell*

In the midst of the coronavirus pandemic, schools and colleges continue to be closed. Parents find their children having to stay at home during long periods of social distancing and lockdown. The home printer is getting a lot more use, churning out learning materials and work being done in the home-based classrooms. Out of the blue, the home printer stops working.

One original equipment manufacturer (OEM) has released a firmware upgrade over the internet that now blocks the printer from working with any cartridge that is not an OEM cartridge. People are already stressed by the upheavals caused by the coronavirus pandemic, wondering how they are going to find food now that supermarket shelves are empty, wondering whether they will lose their jobs, wondering whether they will have money to pay the rent or mortgage, wondering whether loved ones will catch the virus, and now this. Yet another complication that makes things so much harder to bear.

Meet RemaxWorld in Shanghai and Zhuhai in 2020!

China Stationery Fair 2020—RemaxWorld Hall

September 17–19, 2020 | Shanghai, China

RemaxWorld Expo 2020

October 15–17, 2020 | Zhuhai, China



To exhibit, please contact: Victoria Zhao
☎ +86-756-3919263 ✉ Victoria.Zhao@RTMworld.com
More event details, please visit www.RTMworld.com

Visit bit.ly/csfem20 or
scan the QR code
to get free ticket





Should we really be expecting printer lockdowns in a time of coronavirus lockdowns? Let's hope not, but what if they do happen?

Manufacturers often release firmware updates for their devices in order to make sure hardware is kept up to date with new technologies. With increased working from home prompted also by coronavirus, some might argue it might be necessary to update technologies more often. In the case of printers, the firmware is installed directly to the printer and generally contains permanent fixes and features. Manufacturers usually recommend the latest firmware as this may provide significant enhancements to speed and functionality. However, once firmware has been installed, the user is generally committed to that firmware until a new version is released. A firmware update can lock the installed printer cartridge, as well as subsequent third-party replacements, stopping it from working the moment the update takes effect. Most inkjet and toner cartridges today are fitted with highly complicated encrypted devices that interact with the firmware in the printer and without this communication with the printer, the cartridge will not print.

Firmware updates to printers that prevent the use of remanufactured, refilled, and compatible cartridges are nothing new. Such updates are beneficial from the point of view of OEMs, but they can be irksome to end users who use aftermarket cartridges. For chipmakers and aftermarket cartridge manufacturers and resellers, OEM firmware updates are both incredibly disruptive and expensive. If a firmware update is serious enough, third-

party chips must be redesigned, and cartridge manufacturers and resellers must replace cartridges with the old chip design with the new, while fielding customer complaints about the old cartridges no longer working.

Let's go back to that home classroom with the home-schooling printer on the sideboard in the dining room. The parents have been buying remanufactured printer cartridges ever since the printer was purchased. They have a limited budget and the remanufactured cartridges cost much less than the OEM cartridges. The students know that cartridges that can simply be refilled or remanufactured have a much lower environmental impact than the ones that are used only once and then discarded. The OEM releases the firmware upgrade. The printer is

A firmware update can lock the installed printer cartridge, as well as subsequent third-party replacements, stopping it from working the moment the update takes effect.

blocked from working with the remanufactured cartridge. An error message is displayed on the printer sitting on the sideboard: "cartridge problem."

The parents, both of whom have now lost their 'non-essential' jobs in the coronavirus lockdown, during which a quarter of all businesses have closed, can't afford food and rent, let alone pay for more expensive printer cartridges. There are several unused and unusable cartridges now sitting in the sideboard. The students check out the OEM's website, which boasts world-leading sustainability and customer experience credentials. The language

in that dining room when that printer went into lockdown cannot be repeated here for legal reasons.

What might the OEM say to the family in lockdown when a firmware upgrade is released and the use of remanufactured printer cartridges is blocked? The OEM might suggest that it updated a cartridge authentication procedure in select printer models to ensure the best consumer experience. The OEM might suggest that the firmware update was designed to protect its innovations and intellectual property and that its printers would continue to work with refilled or remanufactured cartridges with an original OEM security chip. The problem, of course, is that most third-party cartridges use third-party chips so as to offer fuller functionality and to avoid infringing OEM rights.

Sometimes the printer lockdown may be a result of a pre-set failure-date programmed by the OEM for non-OEM. The situation can be made more complicated because firmware upgrades can also be prompted by upgrades to computer operating systems. The activation of the pre-programmed firmware change can lead to situations in which customers are left with non-functioning printers and potentially a stockpile of unused (and unusable) aftermarket cartridges.

Meanwhile, back in the dining room, the parents and students are getting stressed. This "customer experience" thing doesn't add up. The students check the EPEAT website, which is how they identified what printer to buy in the first place. Manufacturers can register their printers and other products on the EPEAT website so that customers can check the



international exhibition

BUSINESS-INFORM

2020

9th Annual Expo

Work Together Win Together

3-5 June

Moscow

VDNH

bldg. 75

Hall A

Office Equipment
Printing Supplies
Spare Parts
3D printers
Papers



Exhibition organizer
in Russia:

Business-Inform Corp., bizinform@list.ru

in China:

RT Media Corp., Victoria.Zhao@rtmworld.com

EXPO website: <http://sforp.ru/BI2019eng>



environmental credentials of a printer before purchasing it. There it is in black and white, the printer sitting on the sideboard in the dining room is registered as abiding by two mandatory criteria:

4.9.2.1 Allow use of non-manufacturer cartridges and non-manufacturer containers

4.9.4.1 Documentation that the cartridge or container is not designed to prevent its reuse and recycling

These are two of the criteria that were developed through a multi-stakeholder effort that led to the development of the IEEE 1680.2 Standard for Environmental Assessment of Imaging Equipment (amended), the mainstay of the EPEAT

Product Registration system for imaging equipment. Stakeholders included OEMs and

representatives of the remanufacturing industry (such as Int'l ITC, UKCRA and ETIRA) as well as many other organisations and interested parties (listed in the standard).

The EPEAT system allows for product registration according to Bronze, Silver and Gold ratings, with the highest ratings requiring greater levels of environmental performance. For example, a printer registered under the EPEAT environmental standard is required to be designed (criterion 4.9.4.1) so that the cartridge or container is not designed to prevent its reuse and recycling.

Surely, a design modification to a printer, such as a firmware upgrade, that changes the compliance status of the printer with EPEAT qualification criteria effectively invalidates the registration of the printer?

The EPEAT registry is seen by OEMs as an important means of informing potential purchasers of the environmental credentials of their printers (and other electronic equipment). Some purchasing organizations, for example, will only purchase printers (and other equipment) qualified to a particular EPEAT level (e.g. silver or gold) and so an OEM product that has not attained such a registration will not be purchased. Compliance with consumer

protection and antitrust frameworks are of vital relevance to all stakeholders in the EPEAT

endeavour. A product registration that continues to be displayed on the registry but which has been rendered unqualified through firmware upgrade is one that potentially gives grounds for claims of misleading advertising.

Back in that dining room, the students have downloaded a paper on the carbon footprint of remanufactured cartridges compared with OEM cartridges. Each time a printer cartridge is remanufactured (and refilled with toner), one or more of its components may be replaced, although in some refill cycles no components need to be replaced. In Figure

A product registration that continues to be displayed on the registry but which has been rendered unqualified through firmware upgrade is one that potentially gives grounds for claims of misleading advertising.



UK

Douglas Fitzgerald
Inkjet Direct

Your business delivers quality print solutions. It can be a hectic challenge to maintain and develop this offering if the basic print quality doesn't support this intention. As such, part of your core values should focus on the auditing of your supply chain.

Various ISO standards come to mind, however, its essential to gain a strong understanding of the STMC guideline, the ISO print pages and yield tests.

Remember suppliers are delivering these standards in partnership with you. Communicate them, understand them, agree to them.



India

Barkha Mittal
Greenvolution

We are a very customer-centric organization and have invested heavily into product quality. No cartridge leaves our premises untested. We keep up-to-date stock of all the popular printers on a regular basis. Moreover, we have developed our own test sheets which helps us to test greyscale and sharpness in our cartridges to ensure the print quality our customers expect. We avoid as much waste as possible and channel all leftover components through authorized waste handlers.

Service is another very important aspect of our business and we make sure our engineers are professionally trained, by the OEMs on the printers that we offer to our customers.



Romania

Victor Matache
TOKO

We at TOKO use the ISO 9001: 2015 standard. It is a quality management standard and it helps us manage and keep under control of all the procedures we use within the company. This allows us to have a good level of customer satisfaction by ensuring the consistency of services. We are about to implement ISO 14001, which is an environmental management standard.

UNINET

RECHARGE
YOUR ORIGINAL
CARTRIDGES

Absolute[®] **BLACK**

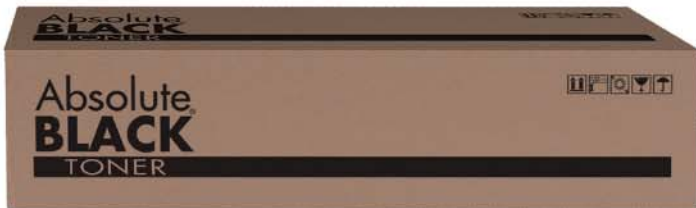

TONER & PARTS

FOR USE IN

HP[®] M404, 428 MFP

- Absolute Black[®] Toner
- Absolute MICR Toner
- Replacement Cartridges
- And More

uninetimaging.com

**CONTACT YOUR SALES ADVISER
TODAY FOR FURTHER INFORMATION**

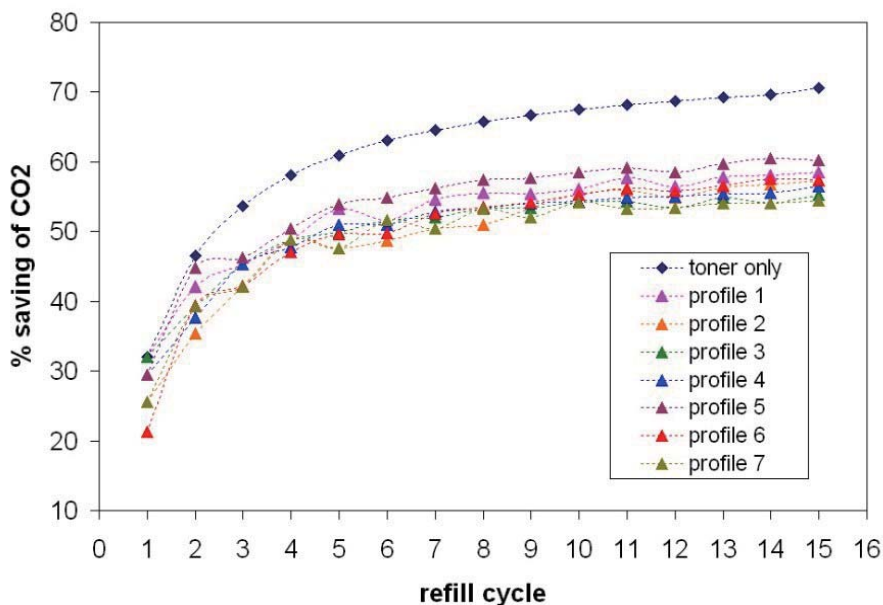

Figure - percentage saving in CO2 emissions of remanufactured cartridges relative to OEM cartridges.

7 of the downloaded paper, the reduction in carbon footprint of the remanufactured cartridge compared with that of the manufacturer's original cartridge. After several cycles, the reduction in carbon footprint has stabilized at about 50 percent.

It is no wonder the family in coronavirus lockdown is concerned about the manufacturer's lockdown of their printer. They purposefully chose an EPEAT-registered printer thinking that it would be able to use remanufactured cartridges, which are cheaper than the manufacturer's original cartridges and which have much lower carbon footprints.

How might remanufacturers be affected? Consumers may return remanufactured printer cartridge products designed for OEM printers. The pre-programming of updates makes it harder for remanufacturers to produce chips that work for the consumer to have confidence in their purchasing decisions and their (corporate) social responsibility intentions. The pre-programming of updates undermines the process of provision of warranty by the remanufacturer on the remanufactured cartridge. This undermines aspirations to develop warranty frameworks for the circular economy. It is noted that according to Regulation 74 of the WEEE Regulations 2013, an emphasis on producers not preventing "through specific design features or manufacturing processes WEEE from being reused, unless such specific design features or manufacturing processes present overriding advantages, for example, with regard

to the protection of the environment or safety requirements."

Clearly the family mentioned in this article is fictional, and the firmware upgrade to the family's printer is fictional, but the issues raised are not. The remanufacturing industry is a well-established industry that addresses a gap in the OEM business model, i.e. the lack of coverage of the remanufacturing stage in the product life cycle, and directly meets customer needs for products with reduced environmental impact and lower cost. The remanufacturing industry relies on the supply of used cartridges into the market. Without their availability, the remanufacturing industry would not have the feedstock on which it relies. In a time when so many parts of our societies are coming together to address the turmoil and distress caused by the coronavirus, there is the opportunity for the imaging equipment and consumables industry to work together to avoid creating further challenges. There is an opportunity through the economic shock that is being triggered by the coronavirus pandemic for manufacturers and remanufacturers to reconsider how they work together to improve the ways in which they provide socially and environmentally preferable goods and services. Even when the coronavirus emergency is over, we will still have the climate emergency to deal with. Companies will be judged and remembered by the decisions and actions they take during this very difficult time. ■

IN MY VIEW

Which standards (quality/ management/ testing/ environmental) do you utilize in your business?



Singapore

Ricky Lee
EOP21 PTE LTD

Our core focus is "Excellence of Product, Performance and People" at world class standards. Over the years, we have designed, developed and set up our own in-house R&D product development methods and testing standards to achieve quality and consistent toner products. Though we have made significant breakthroughs in several of our EOP21 toner products (dual-brand and multi-brand toners), we continue to strive and make improvements with our current systems. Because we do care for our people, adopting Singapore's Bizsafe (Workplace & Health Risk Management) helps us to improve our work processes, efficiency and enhance competency.



Australia

James Douglas
Advanced Consumables technologies

For us, quality is the most important standard to monitor, followed by integrity. We rely heavily on our supplier partners whom, in many cases, are better equipped to provide a higher result in other areas such as environmental and testing. We rely on each other. This is why choosing the right trusted partners with the same, high values is so important. We focus on finding the best products from the most reliable sources as opposed to just trying to be the first to market with whatever is available.



USA

Juan Carlos Bonell
Static Control

Static Control has always been known for its premium level of quality. This reputation was not just built on the hard work of our team, but also on the many quality and environmental standards we use and apply to our manufacturing and quality control. We manufacture in ISO-certified facilities, meet REACH and RoHS regulations, and our quality managers undergo APQP training. I would encourage someone to visit our website and read about the many global standards and regulations that we use.

IN MY VIEW

How are standards being adopted in your region?



Latin America

Gustavo Molinatti

RT Regional Partner for Latin America, Buenos Aires, Argentina

The definition of standards in the Latin aftermarket has always been a controversial topic and the sector has never been able to agree on a general reference standard.

In the early 2000s, cartridge remanufacturing firms opted for various protocols from international organizations like STMC, and eventually ISO.

With the migration to the Chinese new-built cartridges (NBCs) and the abrupt decline in remanufacturing and profitability margins, the application of standards became unnecessary or unfeasible.

Daniel Abbate, president of Silog in Argentina, said, "We rely on 19752—a quality and performance standard involving testing at an Argentine government entity, INTI, who performs measurements based on the said standard."

Vladimir Bossoni, from Tecnotoner do Brasil, claims his company still complies with all ISO 19752 and 24712 certifications and carries out the tests in its own laboratories.

Latino companies that sell finished products, supplies and, perhaps, those that maintain a small remanufacturing line, opt for other standards. ISO 9001 is the preferred one with the objective to improve the performance, reliability and durability of products and services. It seeks to optimize the entire quality management system (QMS) of the company.

Veneta Rosario from Argentina applies ISO 9001: 2015 and also ISO 14001: 2015 to optimize the performance of the Environmental Management System. For his part, Mauricio A. Ruiz de Ecolimp, a firm based in Guayaquil (Ecuador) focuses on corporate MPS. In order to comply with these standards, they also separate "all the components to be discarded, which are sent to certified environmental managers."

Several Latin American entities tried to develop a Quality Seal for their cartridges, especially for remanufactured ones. Argentina made the most progress with this initiative through its Remanufacturers Commission within CAMOCA. They developed a seal (IRAM 12011) that established the characteristics and test methods of cartridges for digital office printers and copiers. However, the cost per stamp made the project economically unfeasible for most companies which had to be built into the price of the cartridge which made the Chinese NBC all the more competitive.

Printing Standards in the Arab World



Dr. George Nubar Simonian



Global Standards

Standards make an enormous positive contribution to most aspects of our lives. They ensure desirable characteristics of products and services such as quality, environmental friendliness, safety, reliability, efficiency and interchangeability.

When products and services meet our expectations, we tend to take standards for granted. However, when standards are absent, we soon notice. When products, systems, machinery and services work well and safely, it is often because they meet standards.

The organization responsible for many thousands of the standards that benefit the world is the International Standardization Organization (ISO). Started back in 1945, it is an independent, non-governmental international organization with a membership of 164 national standards bodies. Today it has 23,147 international standards covering almost all aspects of technology and manufacturing, 164 members representing ISO in their countries, with only one member per country, and 784 technical committees and subcommittees to take care of standards development.

Many can benefit from these standards, for example:

- **Businesses:** where the widespread adoption of international standards means that suppliers can develop and offer products and services meeting specifications that have wide international acceptance in their sectors, therefore, using international standards they can compete on many more markets around the world.
- **Customers:** the worldwide compatibility of technology which is achieved when products and services are based on international standards gives them a broad choice of offers, also benefiting from the effects of competition among suppliers.
- **Developing countries:** international standards that represent an international consensus on the state of the art are an important source of technological know-how. By defining the characteristics that products and services will be expected to meet on export markets, international standards give these countries a basis for making the right decisions when investing their scarce resources.

The ISO standards across all the processes



are constantly being reviewed and updated. They are written to be specific for each process and consumables. With customer quality criteria now being more demanding, companies are being forced to utilize ISO standards as part of their quality control systems. If you do not manufacture to ISO standards, or have gained the certification, you may be denied the opportunity to tender for certain work. Organizations who enforce the use of quality systems are government bodies, local authorities and most importantly international well-known brands and clients.

Impact Upon Printing

Over the last few years, the application of international standards to the printing and packaging industries has gained momentum among a rapidly increasing number of printers around the globe.

The Technical Committee number 130 (TC 130) was responsible for our printing industry’s standards. The Committee has now 101 published standards, 33 under development, 83 withdrawn and four deleted standards. This committee has 21 participating members and 24 observing ones. At present, it has 13 working groups,

recently created groups cover security printing, carbon footprints, postpress and certification requirements.

Middle East Compliance

In Arabic countries and the Middle Eastern region, the printers are more concentrating in obtaining the generic ISO standards for management, documentation, health, safety and environmental, like the ISO 9000, ISO 14000 & ISO 18000 standards. Very few of them started to look at the printing specific standards, only those who are working with international brands and manufacturers were forced by their clients to obtain, use and being qualified to some of these specialized standards.

There is no doubt both kinds of standards are important for us in Arabic countries, since the generic ones are helping the printers to have their work procedures organized and standardized, while the print specific ones are going into deep details of how to purchase raw materials, to process and produce the final printed product in the best efficient high quality specifications and standards.

Therefore, a printer with only the generic standards will give the impression that they



India

Dhruv Mahajan
RT Regional Partner for India

The Bureau of Indian Standards (BIS) is the National Standard Body of India. BIS is responsible for the harmonious development of the activities of standardization, marking and quality certification of goods.

Presence of BIS standard mark (popularly known as ISI mark) on a product indicates conformity to the relevant Indian Standard. Before granting a license to any manufacturer, BIS ascertains the availability of required infrastructure and capability of the manufacturer to produce and test the product conforming to the relevant Indian Standard on a continuous basis.

There is also the MRP or Maximum Retail Price that can be charged to consumers inclusive of all taxes. This standard is applicable across all products including printer consumables under the standard weights and measures laws. Sellers must provide consumer care contact details so that consumer complaints can be resolved.

The various ISO standards are also widely used in India as relevant. Compliance to all standards—ISI and ISO—are mandatory especially for those supplying products to the government. The standards also establish eligibility for large and small project bidding in both the public and private/corporate sector. All banks and funding institutions insist on this as a precondition for granting loans.



China

Peifen Li
Deputy director of the national quality supervision and inspection center for printing and office automation consumables

According to laws and regulations in China, printing consumable manufacturers should execute some standards and regulations to ensure quality and to protect the rights of consumers.

In China, national standards for laser, inkjet and dot matrix printers as well as relevant consumables include:

- GB / T 29301-2012 "Toner cartridges for electrostatic copying (including multi-function equipment)".
 - GB / T 34988-2017 "General Specification for Information Technology Monochrome Laser Printer Toner Cartridges".
 - GB / T 4313-2014 "General Specification for Woven Printing Ribbons for Information Technology Office Equipment Pin Printer".
- Environment standards widely used in China include:
- HJ / T 413-2007 "Technical Requirements for Environmental Labeling Products Recycled Toner Cartridge".
 - HJ 573-2010 "Technical Requirements for Environmental Labeling Products Inkjet Cartridge".
 - HJ 570-2010 "Technical Requirements for Environmental Labeling Products Toner Cartridge".

Certified Quality



Benefits of Certification

Seal of Approval for Cartridges

STMC certification proves that the company certified uses the highest industry-approved standards in manufacturing its cartridges. The STMC logo means that the cartridge in the box has been remanufactured by a company that cares about quality.

STMC stands for the Standardized Test Methods Committee. This global committee formed to find and promote standardized test methods for the printer cartridge industry.

For twenty years, the International Imaging Technology Council has evaluated and monitored the STMC program, fighting for those who use it proudly and against those who misuse it.

Customers demand STMC. Join the hundreds of STMC-certified companies that these customers want to buy from. Get certified today. Contact katie@i-itc.org for more information.



have a very well organized administration, management, documentation, health, safety and environmentally-friendly production, but without the print specific standards there'll be neither evidence nor assurance that the final printed product will be in the highest required quality and efficiency.

So, we're recommending our printers to try to implement and obtain both kinds of standards, which will help them compete in the local, regional and international markets very confidently and efficiently.

Worldwide, about 2,000 companies have been "certified" or "qualified" to an international standard one way or another. As far as we know, in the Middle East, including Turkey, about 15 printing companies and 18 experts have been certified, compared with 600 printers and 130 experts in Western Europe and 800 printers and 400 experts in North America.

Most of these certifications or qualifications refer to process color offset printing, but they also include some flexo, gravure, screen and digital printing operations.

Certification Difficulties and Obstacles

Certification, however, is only part of the story, and research and experience tell us the number of printers already applying these standards, without formal certification, is much higher.

One of the reasons why they didn't opt for certification, so far, is cost. Certifications offered by Fogra, Ugra, and others are not cheap, ranging from US\$4,000 to US\$7,000, to be renewed every two years. But another reason mentioned by printers is the fact that

there is still no universal agreement on the scope and value of the different certification schemes.

Recommended Standards

Some of the main print specific standards which we recommend to our printers in the Arab world to implement and be qualified for are:

- ISO 12647 standard: Process control for the production of half-tone color separations, proof and production prints. It consists of nine parts.
- ISO 12643 standard: Safety requirements for graphic technology equipment and systems.
- ISO 15311 standard: It's the new standard for digital printing, consisting of one part defining the general parameters and measurement methods, one part for commercial printing, and one part for wide format signage printing.
- ISO 10128 standard: Methods of adjustment of the color reproduction of a printing system to match a set of characterization data.
- ISO 15339 standard: Printing from digital data across multiple technologies

There was an attempt to develop standard criteria for conformance assessment including the legal accreditation of certifying bodies. Even if the different parties involved agree on a standard for certification methods, this remains a difficult task, as most of the national standardization organizations are reluctant to accredit agencies for other than the quality management standards in the ISO 9000, 14000, 18000 and 22000 range. ■



Africa

Stuart Lacey
RT Regional Partner for Africa

Africa, like so many other developing regions, is perceived by some suppliers to be a market that generally accepts any quality so long as it is cheap. However, many of the customers have learned that generally you get what you pay for—your cheapest decision often turns out to be your most expensive...

There will always be companies and customers who only want the cheapest possible options—as with any market. Africa, however, is tired of being the dumping ground and there is a general groundswell towards a branded, quality option at a competitive price.

As such, we are seeing more and more resellers, retailers, corporates and end-users demanding superior quality but supported by the requisite warranties/guarantees. The only way this can be assured is by partnering with manufacturers that are signed up to specific world standards and not just doing lip service.

All the general standards are recognized in Africa, but the imaging industry customer base is wanting to see ISO9001, ISO14001 and STMC certifications as a bare minimum. Having RoHS certification and being REACH (EU regulations) compliant are a bonus.

Having said all this, trust and reputation are by far the biggest 'standard' customers want to see if you are to grow on the African continent.

Stuart Lacey



South Africa-based Lacey is a 30-year pioneer of the office equipment and supplies industry and is keen to introduce key global suppliers to the big buyers across the African continent with RT VIP Expo one day intensive events in Nigeria, Tunisia and Ethiopia. Please contact <stuart@delace.co.za>



Pelikan

BIO Based

1211
Pelikan BIO Based
Toner Cartridge

black

For use in Hewlett Packard
LaserJet P1505 - P1505N
M1030 - M1030N - M1032N - M1032NF

replaces
HP
CB436A

SETTING NEW STANDARDS IN EUROPE

—Steve Weedon reveals how new built cartridges meet tougher environmental laws

Industry veteran Steve Weedon is the Chief Executive Officer of Print-Rite Europe Limited, Print-Rite Pelikan GmbH Germany and Print-Rite Pelikan SAS France. “And now for something completely different”



Is it even possible that we could see something completely different in the imaging aftermarket after 30 years? Well, yes. Pelikan, the iconic brand that is 182 years old this year, launches a line of bio-based cartridges.

What is a bio-based cartridge? A toner cartridge made from reusable bio-plastics with a bio-based toner made of 48 percent organic materials, certified by TUV bio-based standards. Lowering CO2 footprint, with all cartridge contents recoverable for reuse, but, if thrown away the cartridge plastics will start to decompose at 90-180 days at 60F and 90 percent humidity, with no loss or sacrifice, to print performance and is cheaper for the end-user than a new, original cartridge.



Pelikan 
 Print it Pelikan.



In 1990 when the remanufacturing industry got underway, it was easy to see the eco-friendly advantages to remanufacturing laser and ink cartridges for resale and reuse. Our vision then was to remanufacture the cartridge for reuse again and again and again. Multiple times in fact. Remanufacturers prided themselves on how many times the cartridge was remanufactured. Seven, ten times. I even heard of 24. Now that does make a difference! Long-life components were designed and made to enhance the eco-friendly program so that the drum would go multiple cycles and the mag roller also. Those were the days that remanufacturers sold directly to the end-user. That's how the cartridge came back time and time again. The eco-friendly, remanufacture for reuse story made sense back then, in the decade of the nineties.

As the remanufacturing industry evolved so did the business model. Bigger order volumes could be had when selling to resellers who were also selling the OEM original cartridge. As the industry business model shifted to

resellers, so did the focus on multiple cartridge remanufacturing. Now, remanufacturers are only interested in remanufacturing a virgin cartridge (one that has never been remanufactured before) and reject non-virgin cartridges. Remanufacturers lost the customer relationship to collect used cartridges for remanufacturing and resale.

Non-virgin empty cartridges need more time and more components to remanufacture which adds up to more cost. More cost but the same selling price means less margin. So, the focus shifted to virgin empty cartridge remanufacturing only.

So, are virgin empty cartridges, remanufactured for reuse, still eco-friendly? At best, remanufacturers can only claim that they delay the cartridge from landfill, or local waste management control, for just one more cycle. That's NOT exactly going to save the planet, is it?

Remanufacturing was at one time the best answer we had to be environmentally friendly with the consumables the market has to offer.

Today however the eco-friendly argument of cartridge remanufacturing is old, worn out and not listened to by end-users. Many realize a remanufactured cartridge is a virgin empty with a new drum and new components added in. The sale is made on price and the customers come back for more if the performance was good. Environmentally-friendly customers will probably put the used cartridge back into a collection program. However, as a non-virgin cartridge, used remanufactured cartridges are usually destroyed or end up in a landfill.

Ten years ago, an effort spearheaded by the late Art Diamond, to make a bio toner was launched. Early iterations produced varied results but only 24 percent of biomaterial content was achieved before print performance degraded. One company, China-based Print-Rite did not give up and continued the research and development.

Today, I am happy to announce that following ten years of research and development at Print-Rite (owner of the Pelikan consumables global license) not only have we reached a 48 percent bio

ratio with the toner but we have also developed a bio-based plastic for the cartridge that has 57 percent organic material content.

So, what does the world's first bio-based cartridge really mean to an eco-friendly end-user company looking for a reduced carbon footprint? What does it mean for those who want to help reduce greenhouse gas, CO2 levels?

- Bio-based certification is a TUV standard requiring more than 20 percent bio content to the product. Pelikan is 48% bio-based on toner and 57 percent bio-based on plastics and is TUV certified.
- HIPs (High-Intensity Polystyrene) is a 100 percent fossil fuel and is used by OEMs. It is not bio-degradable, nor is it bio-based. When incinerated it gives off toxic nitrite and sulphide gases.
- Pelikan bio-based cartridge plastic is made of PLA and ABS thermoplastics. Organic materials like coffee grind, soy, sugars, starch, plants and wood are used. As a thermoplastic, it has the characteristic that at low temperatures, the cartridge plastic can be returned to a usable thermoplastic amorphous liquid that can be reused. When placed under high temperatures there are no toxic gases are given off.
- The tensile strength of bio-plastic is 75Mpa higher than the OEM HIPs plastic which is measured at 23Mpa. This means it's a strong plastic, robust and capable of doing its job in a low-temperature application—perfect for a laser toner cartridge.
- Print Performance. Excellent uniform prints measuring 1.54 density on solid areas.
- Very low 0.5 background.
- Same yield as OEM cartridge products.

Print-Rite Pelikan Bio-based Printer Cartridge: Here is the Sizzle

The Pelikan branded bio-based cartridge is and must be:

1. A Patent Safe Compatible (PSC) cartridge (which means it does not infringe the intellectual property rights of the OEM) and fully compliant with EU and US standards;
2. Certified by TUV and other regional certification authorities.

Once used, the cartridge can be remanufactured using standard components just like the used OEM (virgin) cartridge. Like all Print-Rite PSCs, it is not designed as a Single Use Cartridge (SUC)—another winning feature that meets European standards.

If the cartridge should end up in landfill, the bio-plastic will start to decompose after 90 to 180 days at 60 degrees Fahrenheit and 90 percent humidity. The OEM HIPs cartridge, by comparison, will stay in a landfill without any degradation for hundreds of years.

If the cartridge finds its way into local waste collection systems, the metals can be reclaimed as usual, but the thermoplastics can also be reclaimed at low temperatures without any toxic gas emission and reused as a thermoplastic. Bio-based marks are used to identify the materials.

The Print-Rite manufactured, Pelikan branded bio-based plastic is coloured green for easy recognition and identification. So, it literally ticks all the boxes for customers who follow their company “green” policies to lower CO2 levels and who care about our environment enough to choose the best environmentally friendly product available.

These innovative bio-based cartridges are the best environmentally-friendly products available today:

1. less dependency on fossil fuels means lower CO2, less greenhouse gas emissions;

2. they are compliant with all EU and US standards and local regulations;

3. they use patent-safe designs, supported by 3,000 technology patents developed and owned by Print-Rite.

With 39 years of cartridge remanufacturing experience, the award-winning Print-Rite is recognized as an industry innovation leader. The Pelikan branded bio-based products take the eco-friendly reman to a whole new level. Many experts in the industry are predicting this is a game-changer.

More information on bio-based toner cartridges, contact Steve Weedon, new CEO of Print-Rite Europe Limited, by email at <Steve@prinrite-eu.com> ■

Related

Weedon takes over at Print-Rite Pelikan



Print-Rite Acquires Pelikan's Cartridge Business



Print-Rite Passes the Chinese Government's Strict Post-Coronavirus Examination



Comment

What do you think of this story: Setting New Standards in Europe. Can you see end-users getting excited about this product in your region?

As the leader of a printer cartridge how important are standards for



Association of Japan Cartridge Remanufacturers (AJCR)

No matter how strong STMC accreditation is, it does not always provide total immunity from the powerful challenge coming from the influx of new-build toner cartridges. As an authorized STMC instructor, with my company Hara Trading, I have been supporting the remanufacturing industry and advising end users to develop a better understanding of remanufactured toner cartridges and how those remanufactured toner cartridges will support our society and environment for many years. However,

end users always have the right to choose the cartridges that they would like to use. In order for remanufacturers to differentiate the locally remanufactured toner cartridges from the Chinese new-build toner cartridges, our remanufacturing industry needed a more powerful tool to convince end users to choose genuine remanufactured toner cartridges. The Association of Japan Cartridge Remanufacturers (AJCR) has been promoting its authorized standards and logo, E&Q (Ecology and Quality) for the

toner cartridge remanufacturing industry in Japan very aggressively. The E&Q is only for genuine toner cartridges that pass strict standards. The AJCR does not allow its members to sell new-built toner cartridges. The AJCR commitment has provided a very successful solution for remanufacturers and the remanufacturing industry in Japan. In 2018, AJCR was awarded a Life Cycle Assessment Encouragement Award. ■



International Imaging Technology Council (Int'l ITC)

STMC certification is conferred upon those companies that can prove they use the highest industry-approved test methods in manufacturing cartridges. The STMC logo means that the cartridge in the box has been remanufactured by a company that cares about quality.

For more than twenty years, the International Imaging Technology Council (Int'l ITC) has evaluated and monitored the STMC program across the globe, fighting for those who use it proudly and against those who misuse it. Consumers have learned to trust STMC and they demand STMC. It is recognized and used in more than 80 countries.

The test methods used in the STMC Guide were sourced primarily from ASTM. The ASTM F05 Committee on Business Imaging Products was comprised of members from all sectors of the imaging supplies industry including OEMs and aftermarket representatives. Drafting test methods, that

were acceptable to everyone, was no easy task.

The tests were then added to the STMC Guideline and the Int'l ITC proudly accepted the role of STMC guidelines and committee oversight. The Int'l ITC also rallied interested members to take part in the promulgation of a U.S. environmental standard for environmental purchasing of electronics, called EPEAT. EPEAT has provided a vehicle to call out OEM behavior that is bad for consumer choice and the environment.

In addition to committee participation, the success of the STMC program also requires logo monitoring. With skyrocketing acceptance, STMC also has skyrocketing abuse and misuse. This year, we have documented a number of companies caught displaying the STMC logo when the company, and its products, have never gone through the process. Some companies have made amends but so many more just ignore demand letters. We will pursue and prosecute companies that cheat.

If you are a reseller of certified cartridges, please make sure your supplier is legitimately certified:

1. Check for the company's name on the list of certified companies online (<https://i-itc.org/companies.php>); and/or
2. Verify the four-digit number on the label with our STMC Coordinator at <katie@i-itc.org>;
3. Watch our website and social media for the names of those that misuse our logo.

Please help us police this important program. If you suspect someone is using our logo inappropriately, contact Katie at <katie@i-itc.org>. The Int'l ITC fights for the industry every day, and STMC certification helps us accomplish that.

If you are interested in serving on the STMC committee, please contact me at <tricia@i-itc.org>. I look forward to hearing from you. ■

the association, your members?



Toner & Inkjet Remanufacturers Association (ETIRA)

Cartridge quality has to be the number one priority of European remanufacturers if end-users are to buy a brand other than the OEM cartridge. This is the key business driver for our members. Remanufactured cartridges, marketed by our members, need to be and are the same or better quality as the new product. And we prove that by working in compliance with industry standards. ETIRA members apply the highest quality standards and use internationally recognized test programs like ISO, DIN or ASTM. Our products have been tested for durability and yield, and are guaranteed to work just like the new product, and in many cases have a higher yield

because of the additional ink and toner that is added.

In addition, there are standards that focus on the environment and only reused, remanufactured cartridges have the lowest environmental footprint. Such standards include the Nordic Ecolabel and the Blue Angel (German Ecolabel) DE-UZ177 standards.

In Europe today we see many products claiming to comply with standards, but the non-OEM, single-use cartridges (SUC's) do not. Some affix the claimed accreditation on their products, even when they don't comply,

such as the STMC logo. The DIN standard is often abused too. Some newbuilt, non-OEM cartridges from China carry the DIN logo claiming them to comply with DIN 33870-1 or 33870-2. But these two DIN standards are only for remanufactured cartridges. A new cartridge can never comply with DIN 33870. Such suppliers also use illegal, toxic levels of chemicals in the product's plastics and toners, but claim to comply with the respective European Union RoHS/REACH regulations.

This abuse must stop. ■



United Kingdom Cartridge Remanufacturing Association (UKCRA)

For more than 25 years, UKCRA members have followed quality control procedures that include testing their products before placing them on the market. This is the very basis of guaranteeing your product is equivalent to the original product and at a price that is affordable for consumers.

The standard for comparison has always been the original product in respect of quality and yield. UKCRA members have always relied on their suppliers of cartridge components used in remanufacturing to have the resources to research and develop a quality component, and the expertise, quality controls and labs to produce them.

However, third-party products are being compromised daily—not because of their

product not passing the most rigorous quality procedures and testing, but because of disingenuous advertising campaigns by certain OEMs to discredit third-party toner and inkjet printer cartridges from working in their printers. This includes many discriminatory statements supported by evidence solely commissioned by them to back them up.

Another undeniable problem, in most cases, is the Dynamic Security Feature (smart chip) that controls the registering of the replacement cartridge and the functioning of the printer. UKCRA, along with ETIRA and the Int'l ITC, have sought to address this problem with the Green Electronics Council (GEC) that controls the criteria—and adhered

to by OEMs. The GEC has determined it will be opening a corrective action, which includes revising this criterion. Until such time the users' fundamental freedom of choice to use whichever product they wish in their printers continues to be compromised.

Standards and standardized testing are extremely important and without them, quality will be compromised as will also the health and safety of the remanufacturer and the user as well. Safe alternatives are the backbone of any industry which must also be allowed to offer its products on an equal playing field—unhindered by OEMs and their unfair practices. ■



Static Control Continues to Set High Industry Standards

 *Tricia Judge*



Judge has served as the executive director of the International Imaging Technology Council, a not-for-profit trade association serving imaging supplies remanufacturers and dealers for 20 years. Judge was the executive editor of Recharger magazine. A lawyer for 30 years, Judge also has litigation experience. Judge's work has been published in Recharger, and several other industry magazines, and has won critical acclaim for her writing and industry advocacy. She has assisted in the preparation of six friend-of-the-court briefs. Judge has presented the position of the industry to the U.S. International Trade Commission. She can be contacted by email at <tricia@i-itc.org>

Static Control Components (SCC) has been an industry leader in the production of quality imaging supplies products since its inception in 1987. Its technology is present in nearly every high-quality aftermarket inkjet and laser cartridge in the world.

But SCC never ended its quest of leadership at its own doors. It's been an industry leader on all fronts. It has committed an ocean of resources to all the important legal and lobbying efforts undertaken by the industry. And its employees have held leadership positions on every ASTM, STMC and other industry quality initiatives.

Times are tough...very tough. Instead of focusing inward and only on the bottom line, SCC has instead reached out to see how it can help its customers and its communities. It is once again setting the standard.



SCC is a cartridge and component manufacturer committed to providing the highest quality imaging solutions. It brings the highest value opportunities to the imaging aftermarket by delivering award-winning, localized customer support, global logistics, combined with a relentless pursuit of quality and unmatched expertise in cartridge research and development.

After decades of producing quality cartridge components, SCC knew it had amassed the expertise to build the best remanufactured and compatible cartridges available. Its engineers knew exactly the right combination for perfection in laser and ink jet, given their development of the internal components along with their vertically integrated manufacturing capabilities. SCC builds each cartridge to deliver a premium level of performance that delivers on its pedigree in the aftermarket.

“The decision to start with cartridges truly started with demand from our customers,” said Static Control’s CEO Ken Lalley. “As the variety of printer models available has continued to

increase, most remanufacturers were pushed into a ‘make some/buy some’ model to avoid prohibitive overhead investment. This put them into the position of having to rely on others to provide reliable, high quality cartridges and led to overwhelming demand to Static Control to fill that role. Our remanufacturing customers knew that with Static Control assembling the cartridges, they would be built with the best components and undergo stringent

Remanufacturers shouldn’t lose business because they have to wait for a system of components to be developed and qualified, or for costly empties to become available.

quality assurance steps throughout the process.”

SCC’s system-matched approach to imaging systems allows it to understand and consider every detail within a cartridge, from the electrical charge variances of components to the microscopic additives added to toner, and how it all must work together to deliver beautiful prints from start to finish.

Highest Standards in the Industry

SCC’s state-of-the-art print lab is

where cartridges and components are tested and qualified. Each product is developed using the Advanced Product Quality Planning (APQP)-defined process, a system developed to maintain reliable quality in the automotive industry. Quality tests in environmental laboratories are conducted to ensure that SCC cartridges deliver superior performance no matter the weather, climate or humidity of the printer’s location.

Comparative testing of OEM and other aftermarket offerings are a critical part of our APQP standard. That data guides SCC when setting performance requirements for its cartridges to meet and exceed its customers’ expectations.

SCC’S Total Cartridge Approach Means Higher Quality

As a vertically-integrated manufacturer, SCC engineers research, develop and manufacture the components used to build cartridges. Even before they test their cartridges, SCC’s quality control team have designed the parts to meet exceedingly high quality and performance standards. Each component, microchip, toner and ink goes through



rigorous quality control processes and is system-matched. The cartridges are then assembled using the most advanced techniques to deliver optimal performance. Those cartridges are tested again through a demanding program of quality assurance. This unique approach allows SCC to control every step of production to meet the highest quality standards.

SCC's AllPage cartridges are an example of SCC's solutions-oriented, quality-driven product development. AllPage technology is a cartridge, chip and software combination that accurately reports the number of pages remaining throughout the entire life of an extended yield cartridge.

To create AllPage cartridges, SCC has teamed up with software solution provider ECI FMAudit to develop an exclusive opportunity to end toner waste and increase MPS profitability. MPS analysts have found that 15 to 30 percent of toner remains in so-called empty standard cartridges, and even more in jumbo or extended yield cartridges. AllPage Technology reclaims that wasted toner. AllPage Cartridges truly lets the consumer "get what he paid for" and recapture lost margins.

By offering the aftermarket a wide product catalog, components, remanufactured and compatible toner and ink jet cartridges, it is the industry's one-stop-shop for all their imaging needs.

"We offer a very unique solution. We can provide remanufactured cartridges for areas where there may be increased concern for IP or our engineers haven't been able to qualify a suitable product through compatible offerings," said Lalley. "That being said, we also accept the fact that compatibles offer many first-to-market opportunities. Remanufacturers shouldn't lose business because they have to wait for a system of components to be developed and qualified, or for costly empties to become available. We looked at the industry and saw that there was room for massive product improvement in the compatibles available and this is where we saw our opportunity. We can bring a quality solution to market for those seeking a high-quality product at a competitive cost through the use of our industry-leading componentry in our compatible line."

In addition to its cartridge line, Static Control is still the industry

5 QUESTIONS

Static Control's General Counsel Elizabeth McKee Responds to Questions from Tricia Judge



Elizabeth McKee
Static Control's General Counsel
< bethm@SCC-INC.com >

1 Congratulations on the victory in the Canon Case. Tell why it was so important?

We felt this case was very significant because of the overreach shown by the OEM. Once a patent is granted, you only have the rights to what is claimed in the language of the patent – plain and simple. What we saw in this case was the OEM attempting to expand the scope of its patent after the fact to cover aftermarket innovations. We could not let this overreach happen. It's simply not right and we aimed to stop it.

2 The victory could be interpreted as a loss for remanufacturers, since it benefits the new-build community. What is your position on that?

This is a key win for the entire aftermarket. Any time an OEM is granted a patent that involves a component for a printer cartridge, it has the potential to impact us all. Having the ability to utilize aftermarket innovations is important for those that sell components, as well compatible and remanufactured cartridges.



Capture Insights of the Global Imaging Supplies Market

—Explore incredible possibilities for your business

Market Insights
Time-saving
Video Lectures



Diligent Global
Consultant Group



Contact: Victoria Zhao

© +86-756-3919263

✉ Victoria.Zhao@RTMworld.com



leader in providing components to remanufacturers around the world. The company regularly releases new chips, toners, drums, blades, and even other items that are necessary like felts, foams and seals.

“We have and will continue to support our remanufacturer customers through the development of new components, such as chips, toners and drums,” he said.

SCC Sets the Standard for its Team as Well

After 30 years of being at the forefront of the industry, SCC employees are dedicated to providing the best solutions. From its engineers, sales support staff and manufacturing employees, SCC has built a reputation as the quality leader of the imaging aftermarket. The team has been devoted to bringing products to market swiftly and efficiently.

Customer support is delivered by an experienced SCC representative familiar with his customers’ needs, in a personable, dependable manner. SCC’s customer service members routinely win industry awards for the top-notch support they provide. SCC’s technical support team is also ready to assist with any product needs. Their in-depth knowledge of all things printing helps customers troubleshoot common – and uncommon – problems. Recently, that has meant being familiar with unwanted firmware

upgrades and relevant solutions.

More Support: Laptops, Masks for North Carolina

SCC’s team members bring heart to their work, and now they are bringing heart to their workplace. Since 1987, SCC has been a dominant employer in the Sanford, NC area. It is no surprise that when COVID-19 showed up, SCC stepped up to help its community. SCC donated 25 used HP laptops to Lee County Schools to help provide computer access to children who otherwise wouldn’t have access to a computer during the coronavirus.

Also, in the wake of the coronavirus outbreak, Static Control has donated masks to area medical facilities. In general, there has been a huge shortage of masks, gloves, gowns and other personal protection equipment (PPE) to medical facilities throughout the United States and world.

The closest hospital to Static Control’s headquarters is Sanford-based Central Carolina Hospital. Static Control sent 650 masks to its emergency room department to help combat the disease in the area. It also donated 650 masks to FirstHealth Moore Regional Hospital, another area hospital about 30 miles from Static Control; 150 masks to FastMed Sanford, an urgent care facility; 150 to Sanford Pediatrics; and 150 masks to Pinehurst Medical/Sanford

5 QUESTIONS

Static Control’s General
Counsel Elizabeth

McKee Responds
to Questions from
Tricia Judge



Elizabeth McKee
Static Control’s General Counsel
< bethm@SCC-INC.com >

3 Firmware upgrades that vex aftermarket cartridge use are the latest legal problem. What are your thoughts on the firmware issue?

The OEMs have used firmware to try to lock-out the aftermarket for many years. We will see this trend will only continue but like always, the aftermarket will persevere through innovation. Our research and development team works tirelessly to continue to offer replacement chips that are the most resistant to firmware changes from the OEM.

Static recommends against updating any printer with the latest firmware. We’ve been informing our customers for a very long time that this is one of the best measures to prevent against lockout. We have a dedicated firmware page on our website which warns of upgrades and can provide more information.

It’s important to also buy replacement chips from a reliable supplier, like Static Control. We have dedicated R&D teams that work on firmware issues. There have also been class action suits targeting OEM behavior. The aftermarket should and will continue to stand for the rights of the consumers to choose the products that they want to use.

RT MEDIA DIGITAL PRODUCTS AND CHANNELS

Social Media



ID: recyclingtimes
20,000+ followers



ID: Recycling_Times
18,000+ followers



ID: RT Media Co., Ltd.
8,000+ followers



ID: intouchnews
67,000+ video views



ID: Recycling Times Media
22,000+ video views



Chinese Toutiao App
76,000+ annual page views



WeChat ID: i3dpworld
57,000+ followers



WeChat ID: irecyclingtimes
17,000+ followers

InTouch Weekly Newsletter

50,000+ Newsletter Subscribers, in Chinese, English and Spanish



Please contact:

Victoria Zhao / Victoria.Zhao@RTMworld.com / +86-756-3919263

www.RTMworld.com



Medical Group. All of these medical facilities help provide services to Static Control's employees and families.

In addition to donating to medical facilities, Static Control provided masks to employees and their immediate family members who worked in the medical field or had a high risk for contracting COVID-19. More than 700 masks were sent to employees to help protect themselves in the wake of the virus.

A Guiding Presence in the Aftermarket

At the crossroads of SCC's giving philosophy and commitment to industry leadership is SCC's legal department. Since the industry's inception, SCC lawyers have been involved in every major industry legal battle. SCC took on Lexmark in 2000 over Lexmark's prebate program and battled the OEM for more than a decade. SCC was one of only a handful of aftermarket players that took part in setting federal environmental purchasing guidelines in the EPEAT process. SCC has been instrumental in all the dongle gear litigation with Canon.

SCC recently secured a key win in the U.S. Court of Appeals for the Federal Circuit with the decision made on April 20, 2020 in Canon Inc. v. ITC.

"We see this as another huge win for the aftermarket," said Static Control's General Counsel Elizabeth McKee. "This decision upholds the ruling that Static

Control's products did not infringe the asserted Canon patents. Specifically, this was a Rule 36 affirmation, which means the evidence presented to the Federal Circuit was so clear that the Court did not believe it necessary to issue a formal opinion." For Canon to pursue this matter further they would either need to seek review en banc with the Federal Circuit or file a petition for certiorari to the United States Supreme Court.

"As always, Static Control will continue to defend the aftermarket and remain vigorous in our defense of designs which do not infringe valid claims of OEM patents," McKee said.

Future Standards

In these troubling, tumultuous, uncertain times, it's important to have companies like SCC leading the aftermarket into its next chapter. The industry can count on SCC to set high standards for the rest to follow.

"We are excited for what the coming years will bring to the industry," said Lalley. "Our research and development team have the latest and greatest in high-tech equipment to help them remain at the top of their game. We will continue to innovate and bring new solutions to market, and we will do all this while providing top-notch service to our customers." ■

5 QUESTIONS

Static Control's General
Counsel Elizabeth

McKee Responds
to Questions from
Tricia Judge



Elizabeth McKee
Static Control's General Counsel
< bethm@SCC-INC.com >

4 What other legal issues is SCC watching on the horizon?

Static Control is deeply committed to compliance with global regulations around the world. We saw its importance in the last couple of years with decaBDE and the recent increase of regulations around the globe. We suspect we'll see tightened regulations in the United States. We continually remind our customers that is important to know your supplier and understand their supply chain. Our product line is ready and we are compliant, however, we've tested other aftermarket solutions from competitors and know that others are not.

While not directly a legal issue, we're all also anxious to see the impact of COVID-19 on the industry. Our number one priority has been keeping our employees and customers safe.

5 Congratulations on succeeding Skip London as SCC's General Counsel. How do you feel about your role in the industry?

Thank you, I accepted the GC position in April 2019 and the first year has been very rewarding, especially with the recent Canon win. I have learned a lot from Skip through the years and he's been a great mentor and friend to me. I am part of a great leadership team that will continue to carry Static Control into the next phase of growth while continuing to defend the aftermarket in the years ahead.



Generating more leads for sellers!
Easier to use! More products! More sellers!

 **ombe.com**
Office Machines & Business Equipment

Reaching more buyers in North and South America than any other industry website.
Sign in and start today!

Welcome to Ombe.com

- More Office Machines, including Copiers and Printers than ever before
- More Multifunction Copiers and Printers
- Expanded Cartridge, Parts, Supplies and Service

PayRede™

- Now you can use *PayRede™* to Place an Order, Request for Quote (RFQ) or to Request More Information
- A copy of the order is stored in the buyer's 'Sent Items' folder
- A copy is sent to the seller by email
- The seller may respond by email or phone.

- Use it as often as you like—it's Free
- Easy to use
- Available 24/7
- Fast
- Any Language
- Accurate

- OEM
- ALSO SOLD AS IS
- COMPATIBLE
- NEW
- USED
- AS IS



TO GET STARTED CONTACT

ADVERTISING SALES

417.781.9317, ext. 215
800.825.9633, ext. 215
advertisingsales@asaypub.com





Ray Stasieczko

Meeting Standards Means Staying Relevant

Nothing focuses the mind more than a virus attempting to whip your business off the map.

The print equipment and services industry has had its share of warning signs regarding its end-users' transition to a more digitized world. Unfortunately, the industry's procrastination to deal with these realities put them in a terrible place. Now all those who procrastinated their digitization are being forced to adapt quickly for survival.

This pandemic has moved the digitalization of the office ahead by at least five years. So, the question is—will the industry meet the new standards for relevance?

First, we must explore what the new relevance will be. Over the last half-decade, the document imaging industry has participated in some extremely illogical thinking. The manufacturers and those who sell and service their equipment have attempted to defy the decline by buying each other up and adding more declining revenue to their top lines. While at the same time not adjusting to the needed cost controls to improve bottom lines.

Buying a competitor's businesses in a declining marketplace without diversification is extremely dangerous. If their bet was reselling before the collapse of an industry, they lost the bet.

Will this pandemic prove to be the needle that burst the hyper bubble of the industry's roll-up obsession? I would conclude it will alter the stakes and the stakeholders in ways unimaginable to most. I have been a voice asking questions to the industry for over a half-decade. Sometimes these discussions brought forth arguments. Unfortunately, not enough arguments and not enough asking questions.

What are the new standards for accountability in an industry which will face



its toughest time in history? "The document imaging channel" or what I believe we should call the "print equipment and services industry" has lost focus on what their core deliverable was.

For the last decade, the industry oversold equipment as the end-users needs of dependency on the machine continue to reduce. They attempted to diversify into services outside print and never really gained momentum doing that. Many believed changing the name of the industry would change the game of the industry; they were wrong.

We still see the industry's manufacturers and dealers obsessed with A3 MFP equipment. All the processes and manufacturing benefit from their overselling of A3. The manufacturers have been attempting to recreate the relationships their end-users used to have with equipment ten years ago with silly apps and gimmicks, which are not at all accomplishing the goal of increasing volumes or bringing the printer/copier equipment a new relevance. Many manufacturers can not admit to or respond to market realities.

I, as most in the industry, must be amazed as we continue listening to the new-leadership at HP talking about their aspirations in selling the oversize mostly unneeded A3 copiers/printers. HP's thinking is

that they will disrupt the A3 marketplace at a time when end-users are making shift to A4. Examples like this are the greatest threat to many manufacturers in the industry. Too many are hoping that things remain as they once were. HP is over a decade late to the A3 party.

The standards of relevance are not anywhere in-line between end-users, the manufacturers, or the dealer channels who sell and service the end-users. The more significant distribution model is what Tech Data, CDW, and yes, Amazon and Alibaba are doing well: delivering to the market based on market buyers' realities.

"The industry's leaders must create visions of the future through what they see in front of them over creating visions from memories."

We all know well the commoditization of print equipment. Unfortunately, it has been ignored by manufacturers in their direct operations and nearly all the dealers who deliver and service end users.

Change has happened, and this change will rush through the industry. The change is the new awareness end users have faced through this global pandemic. End users now have confirmed that print equipment or MFP equipment is not critical to a majority of business processes, and the processes that were dependent on print were quickly replaced with 100 percent digital applications. ■

Over the last 25+ years, Ray Stasieczko has called the imaging industry (copy/print) home. He was COO/ Vice President of ImageQuest over the past years. Ray has a deep understanding of the transformation happening in the industry, and his rich experiences allows opportunities for others to navigate through the transformation. <raystasieczko@gmail.com>



Teddy Chen, an imaging-industry veteran, is the founder and CEO of ITS. He has a deep understanding and vast knowledge of international business, particularly in the field of compatible printing consumables. He is regarded for his leadership skills and ability to identify and catch strategic business opportunities. For enquiries contact Chen at [<info@its-service.cn>](mailto:info@its-service.cn) or visit the website at www.its-service.cn.

Trust — Looking for Products in China that Consistently Maintain Quality

 *Teddy Chen*

One of the things I hear most about China is the concern for quality products. Of course, there is no problem in finding quality products, but most international buyers have had a bad experience. They tell me that what they received was not what they expected.

Others say that the first shipment is fine, but those that follow are “just horrible.” There is no consistency in the quality.

Some say they take the time, and at great expense, to travel to China to source their products, visit the factories, talk with the production supervisors and managers. They still receive a “mixed bag” of excellent and poor products.

China has the ability to design and build the best smart phone devices, the fastest and safest trains, aircraft, motor vehicles and even spacecraft that can land on the dark side of the moon. So, if quality is not a problem, why can't I find someone I trust to help me deliver the quality, and the quantity on time?

Well now you can.

It has been well established that Zhuhai is the world capital of printing



consumables. It has an unparalleled advantage of supply chain integration for aftermarket imaging supplies. As the leading exhibition service provider for office equipment and aftermarket imaging supplies, RT Group is eager to bring value-added services to the industry and to help develop the industry in a healthier and more sustainable way.

RT, the company you already trust with its magazines and events, has partnered with Integrity Team Service (ITS)—to deliver a service you can also trust. ITS offers customized testing solutions to help buyers verify the product quality they imported from China.

Businesses are increasingly looking to move beyond the minimum regulatory requirements and are turning to the testing and inspection industry as a reputational and operational enhancement mechanism.

To this end, ITS was born, with an

inherent sense of mission to create value for the industry and society. Its main business scope includes five parts:

1. Factory Audits

ITS can conduct a comprehensive evaluation that includes, but not limited to, productivity, quality control systems, management systems, technical levels, manufacturing processes as well as work environments to help customers fully understand their suppliers.

2. Formula Checks

The testing mainly includes the fitness of each component including print performance (density, color saturation, page yield, transfer rate, etc.), temperature testing, humidity testing, storage testing and vibration testing. You may have additional testing procedures you require and these can be included.

3. Cargo Inspection

a. Initial Production Check (IPC)—IPC is performed on five to ten percent

of the initial products that are finished and ready for inspection, allowing a review of product quality requirements before mass production begins or the rest of the order is completed. Permit timely corrections of any non-conformity detected, and improvements action to be made prior to the commencement of mass production.

b. During Production Inspection (DPI). DPI is performed at the stage when 30 percent to 50 percent of the goods are finished and packed into export cartons. This inspection validates the initial production process has been maintained and that goods being produced continue to meet quality requirements. In the case of new raw materials, new operators, production lines or specification changes, this service can assess if requirements are being met during production.

c. Final Random Inspection (FRI). FRI is a most effective inspection that confirms the whole shipment's



quality level. It normally requires the production to be 100 percent complete and at least 80 percent of goods packed into cartons. The checked samples are randomly selected according to the AQL standard.

4. Loading Supervision

Loading supervision provides witness to the loading process, to make sure the correct quantity is loaded and to check the quality and condition of the cartons being loaded into the containers.

5. Patent Consultation & Assessment

a. Patent consultation: provide relevant patent information about products facing current patent disputes in the industry. ITS will also check if suppliers have alternative non-infringing products for replacement.

b. Patent Assessment: checks on patent ownership, patent validity, country of application and the key points of patent rights.

According to the China Market Research Network, the demand for global toner cartridge shipments will grow from 379 million to 479 million cartridges in 2020. With OEM cartridges occupying more than 70 percent of the market share—meaning compatible cartridges account for less than 30 percent—it's a signal that consumers prefer to buy product solely based on quality, instead of price.

Quality is Critical in Satisfying Customers

If you fail to meet customers' expectation, they will quickly look for alternatives. Quality is critical in satisfying your customers' needs and retaining their loyalty so they will continue to buy from you in the future. Quality products make an important contribution to long-term revenue and profitability through repeat business. When you sell quality you can charge a higher price because consumers trust your product will always deliver. There

is no such thing as the highest quality cartridge available at the cheapest price. You should be planning to sell at higher prices, with better margins when you have a quality product. Quality is the key differentiator in a crowded market. It's the reason Apple can price its iPhone higher than any other mobile phone in the industry, because the company has established a long history of delivering superior products that people trust.

Establish Your Reputation

Quality reflects on your company's reputation. The growing importance of social media means that customers and prospects can easily share both favorable opinions and criticism of your product quality on forums, product review sites and social networking sites, such as Facebook and Twitter. A strong reputation for quality can be an important differentiator in markets that are highly competitive. Poor quality or product failure that results in a product

REACH THOUSANDS GLOBALLY WITH YOUR BRAND



- This maybe the most POWERFUL marketing tool for your business!
- Video and TV reaches more people than any other channel

ADVERTIZE ON **RT** inTouch TV

And much MORE!



67,000+ views



22,000+ views



86,000+ views



53,000+ views

For advertising, please contact: Victoria Zhao

📞 +86-756-3919263

✉ Victoria.Zhao@RTMworld.com

www.RTMworld.com



recall campaign can lead to negative publicity and damage your reputation.

If your business consistently delivers what it promises, your customers are much more likely to sing your praises on social media platforms. This not only helps drive your brand awareness, but also creates the much-desired Fear Of Missing Out (FOMO) effect. Social-media users that see your company's strong reputation will want to become a part of the product or service you're offering, which can boost your sales.

Manage Costs Effectively

Poor quality increases your costs. In some cases, you may have to scrap defective products and pay additional production costs to replace them. If defective products reach customers, you will have to pay for returns and replacements and, in serious cases, you could incur legal costs for failure to comply with customer or industry standards.

We believe there are disastrous

encounters for all the buyers, including you. I hear many sad stories. One such story starts with a sample request.

Testing identifies the product did not meet the standards you expect.

The vendor simply replies, "No problem, we will send another sample."

The second sample shows some improvement but still does not meet your specifications.

The vendor often replies, "No problem we will send another sample."

The third sample shows further improvement and actually meets your specifications and expectations. With this third sampling, you believe you have landed that "Holy Grail" vendor and product. However, that's not the end of the story and what follows cannot be put into print.

Each sample had improved in print quality because it was using different, higher-quality components. But in so doing, it also eroded the supplier's margin. Ten containers later you finally

had the business relationship you had hoped for with a supplier delivering the expected quality consistency.

Guess what happens next?

Someone changes the specification or the formulas in the factory. The quality suddenly takes a nosedive, and the relationship with the vendor goes sour because they chose to risk the relationship and business volume by changing your approved build model components with cheaper ones to increase their margin per cartridge.

What happens now?

ITS has been established to cure your headaches. We will confidentially expose the good and the bad. Because we know that both do exist. Our role is to assure our clients that you will always get the quality you expected and requested at the price you agreed upon.

If we can make you feel right, the rest is easy. If you can make your customers feel right, the rest is easy too. ■

IN MY VIEW

Why are standards important to you as an authorized STMC trainer?



South Africa

Coenie Greyling

If there is no standard, how can the performance of the product be measured? Imagine if there were no standard for the rubber used in vehicle tires, and that they had to conform to no standard? You would end up with a heap of problems that could risk your life.

A cartridge that has gone through the STMC criteria gives a clear indication of not only the performance of the cartridge but also the company that backs the product.



Russia

Alexey Samoshkin

Evaluating the performance of toner cartridges is the task of all manufacturers and remanufacturers. It must be done. Standardized testing should help them get a relevant evaluation using best practices - no serious mistakes, good accuracy and repeatability. Also, standardized testing can save time spent on building your own testing procedures and allow then industry to speak one language with suppliers and partners adopting the same standards.



USA

Bill Henry

STMC gives focus to what we do as remanufacturers and resellers of laser printer toner cartridges. The only way we can survive is to match or beat the OEMs quality and performance. Standardized testing is the most effective tool we can use to aggressively compete with the OEMs in the quest for toner business!

COVID-19: Accelerating Print Industry Transformation

 Louella Fernandes

Study details

Quocirca received 114 completed responses, 26 percent from OEMs, 54 percent from channel organizations and 18 percent from independent software vendors (ISVs). The rest of the respondents fell into the 'other' category. For the purposes of this report, where splits have been reported, they are focussed on OEMs, channel partners and ISVs. Overall, 72 percent of respondents were from organizations with fewer than 1,000 employees (65 percent in the first survey). Fifty two percent of respondents were from European organisations (against 44 percent), 16 percent from the US (27 percent) and 32 percent from other regions (29 percent). Quocirca plans to repeat the survey again, either in whole or in parts with additional questions, so changing sentiments can be tracked and priorities among print industry leaders better understood.

Key findings

- Office print volumes continue to fall, but demand has increased in the healthcare and government sectors.** Overall, 68 percent are seeing/expect a significant decline in print volumes, with a further 27 percent seeing a marginal decline. However, 54 percent of respondents are seeing increased demand from the healthcare sector, while 63 percent are seeing a decline in demand from business and professional service customers (66 percent in the first survey).
- A catalyst for change.** Office print industry players recognize that they need to rapidly adapt to survive and thrive. Sixty-six percent state that they will need to change their operating model going forward (up from 57 percent). Fifty-eight percent (up from 47 percent) plan to introduce new products and/or services to market.
- The majority have not made permanent terminations.** Overall, 68 percent have not laid off any employees, with only seven percent having laid off more than 50 percent. Maintaining employee numbers is weakest in the channel, where 8 percent have laid off more than 50 percent of their staff. However, many organizations will have furloughed staff, making use of government initiatives. Further terminations could well follow later.



Quocirca conducted a snapshot online survey between March 31 and April 7, 2020, to understand the impact of COVID-19 on the office print industry. This has now been followed up by a second run of the survey, carried out between April 8 and 23, 2020. The research looked at the perceptions of a range of office print supplier organizations to understand the impact of the COVID-19 pandemic on their businesses. The latest survey reveals that while the office print industry remains significantly impacted, most believe that the pandemic will be a catalyst for change through innovation of products and services.

Please visit Quocirca's COVID-19 resources at <https://quocirca.com/covid19-market-insight/>

- **Channel respondents are struggling and need more support from suppliers.** Sixty-one percent state that they now need financial support from suppliers, an increase from 39 percent in the first survey. The need for supply chain updates seems to be declining, with 45 percent stating this as an issue now, compared to 55 percent in the first survey.
- **Most expect business recovery to be slow.** The findings as to when respondents expect to get back to a normal working environment are strongly aligned between the two surveys. Twenty-one percent of respondents are cautiously optimistic that business could return to normal in less

than three months. However, 35 percent expect it to take six to twelve months. Twenty-three percent expect it to take longer or do not believe that there will a "business as usual."

- **Cloud and collaboration opportunities abound.** Both surveys indicate an increase in customer interest for collaboration and cloud-based digital workflow tools. However, 30 percent expect interest in MPS to decrease. Marked increases are evident for device as a service (DaaS) and secure printing solutions.

Mixed outlook for future recovery

No one is currently able to predict when

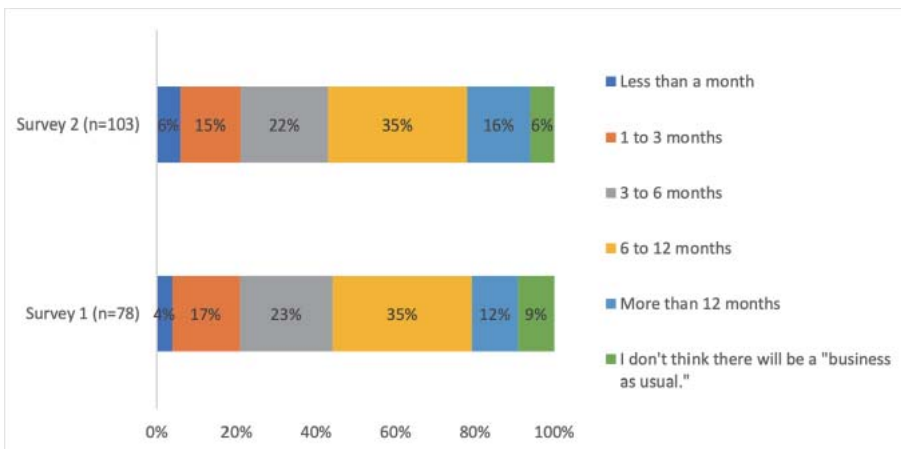

Figure 15: How long would you estimate it would take for your company to get back to business as usual once the COVID-19 crisis has been brought under control?



USA

Mike Josiah

The STMC was formed in response to a need for a standardized way for remanufacturers to test their aftermarket cartridges, as well as the OEM cartridges, so a fair, scientific comparison could be done. Without a standardized testing system like this there is no real way to know how a company's remanufactured cartridges actually run as compared to the OEM. These test results allow the end user to have a valuable resource when deciding on what and where to purchase.



Japan

Masato Emori

As a result of spending time on STMC over many years, I have found the STMC standards have become an important consideration for Japanese companies or government offices who purchase remanufactured toner cartridges. STMC does not guarantee the quality of any particular remanufactured toner cartridge. However, end users would like to source reliable, consistent quality remanufactured cartridges from STMC certified members who are knowledgeable about the standardized testing method.



ImagingWorld

The Most Trusted Name in Print in 5 Languages

Looking Behind the News

Extract (Multi-languages)

Arabic



Russian



Spanish



Industry Directory



English



Chinese

www.RTMworld.com

QUOCIRCA

COVID-19: Accelerating Print Industry Transformation

Quocirca Business Impact Tracker Study (Second Edition)

Survey conducted between 8th April and 23rd April amongst print industry executives. 114 respondents participated from a mixture of OEMs, Channel Partners and ISVs

[DOWNLOAD EXECUTIVE SUMMARY FINDINGS](#)

www.quocirca.com

Impact of COVID-19 on business

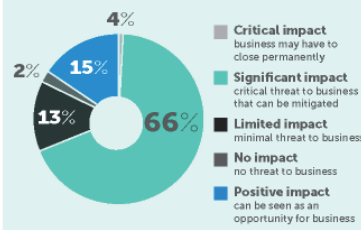

Market disruption will drive innovation

Agree or Strongly Agree responses

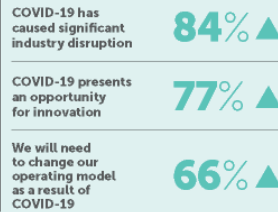

Office print volumes are in free fall

What impact are you seeing on customer print volumes?

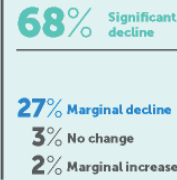

Vertical demand varies

How is demand changing by industry sector?

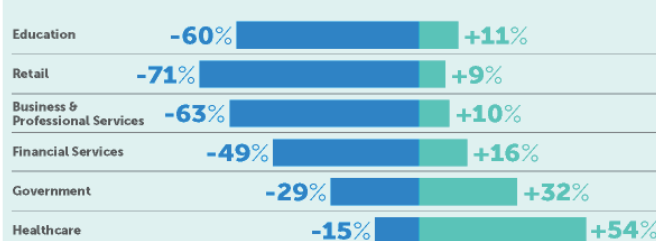

Collaboration, cloud and digitization opportunities

Anticipated future interest

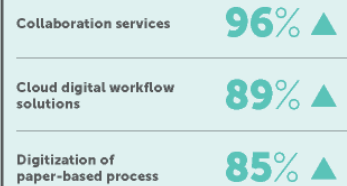

Channel partners expect more support from their suppliers

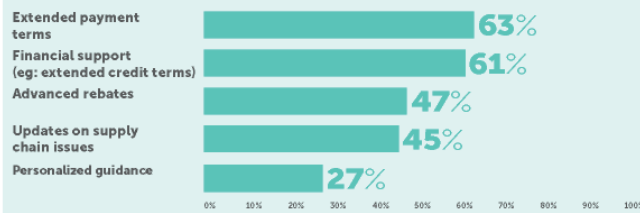

Most are cautious about business recovery time

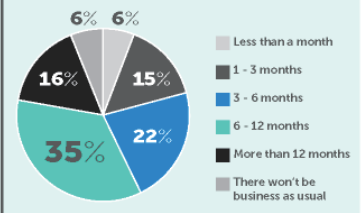

the pandemic will be brought under control and if, and when, the print industry will swing back to its pre-crisis level. Overall, there is a high degree of agreement between the first and second runs of the survey. However, there is a small growth in those expecting to get back to business as usual in under a month (six percent against four percent).

A minority are cautiously optimistic, with 21 percent expecting it to take less than three months to recover – unchanged from the previous study (figure 15). The majority, though, have a gloomier outlook, with almost 60 percent expecting it to take more than six months to recover. This, of course, will vary by country and business size and how confident a business is about their ability to bounce back. There may also be some degree of confidence due to the expected benefits of government stimulus plans.

The fact that half of respondents believe it will take over six months reflects the

continued uncertainty that print vendors and their channel partners are facing.

What is certain is that print manufacturers will feel the impact of the pandemic throughout their entire operations. COVID-19 will not only jeopardize supply chains and business demand for printing but will also shake up the innovation cycle of the whole industry.

Undoubtedly, a new era will be heralded when it comes to working patterns, with the increased need for flexible working that bridges the gap between home and traditional office workspaces. The office will be essentially reinvented, and print vendors will need to scramble to remain relevant in the post-COVID-19 workplace. To respond to opportunities, office print vendors and their partners will need to pivot their businesses and, in many cases, forge new relationships to help fill gaps in their portfolio.

New services and functions will be required. Hosting these in the cloud will

make them more flexible and applicable to emergency use during such a crisis period. Enhanced communications and collaboration systems will become a necessity. More automated workflows with better information capture and straight-through processing will be sought by customers. Artificial intelligence will enable vendors and customers to better deal with maintaining a working environment. There is plenty of scope for the print market to create new opportunities in the unfolding world during and after the current crisis.

Technology and service partnerships were already becoming the cornerstone of an effective response to accelerating digital transformation and will only become more imperative as the shape of the new business normal becomes apparent. Those businesses that retool their environments and working practices for tomorrow will avoid extinction and even thrive after the pandemic is over. ■

5 QUESTIONS

Using Standards to Market Products

—HYB Sales Director Kim Lee says standards are critical for a product to achieve market success.

When did HYB first use standards? And why was it important?

Ever since we began production, standards have been critical and exist as a logical tool to minimize confusion within organizations and provide a foundation upon which we can continue to improve our products. HYB has a reputation for conducting thorough intellectual property (IP) research and development in the toner and cartridge industry. We have set a high standard in the manufacture of injection and blow molding and today we have 2,700 cartridge SKUs for copiers. We know all too well the successful functionality of the whole cartridge is dependent upon each material we select, whether it be a PVC film, foam or seal. Merely copying the OEM will not provide us with a final product that will satisfy our customers. Having a standard to measure and identify each component and raw material is the only way to establish a bill of materials list to build a superior product.



Kim Lee, Sales Director of HYB, <kim@haoyinbao.com>

Which key standards are you using now?

When it comes to environmental and management standards, we rely upon ISO 14001:201 and ISO 9001:2015. The test standard IEC 62321:2013, EN 55014-1:2017, EN55014-2:2015, EN61000-3-2:2014, EN61000-3-3:2013+A1:2019, EN60335-2-2:2010+A11:2012+A1:2013, 10-RING environmental-friendly standards also play a key role too. At HYB, we have also developed our own unique and more sophisticated quality systems—much stricter than ISO 9001:2015—to set even higher standards on our products.

Why is it important for aftermarket suppliers like HYB to follow standards?

There is an industry perception that the composition of copier toners is much simpler than laser toners. An illusion exists that it must be easier to produce copier toner cartridges. As a result, many manufacturers of laser toners have jumped into the copier industry expecting it to be “profitable” and “easy” with “low engineering and technical know-how.” Consequently, many failed. They couldn’t provide consistently stable, quality products and created a high technical service cost to their customers. For this reason, manufacturers should meet product performance standards that can be measured and compared with OEM products. HYB is not satisfied to simply offer “workable” cartridges but to also consider care for human health. HYB insists on using premium plastic granules that meet environmental standards and do

not contain toxic levels of decaBDE and other harmful chemicals. A recent LGA emission test of eight competitor products purchased through Amazon all failed because of the harmful levels of chemical contents (including naphthalene and cobalt) in the toner. It is the reason why HYB insists on using qualified premium toners that passed LGA emission tests.

Are standards important when it comes to market your products and do end-users really care?

Yes, certainly. Standards are an integral part of quality control (QC) procedures as is also the case with supplier management, maintaining consistency and tracking methods. The benefits distributors and dealers receive from products is having conformity with standards and will continue to provide products and services with consistent quality for their customers, the end users. These end users will know whether those products satisfy their needs or not. This is how brands or products impress customers. In our new product announcements, we don’t just make pronouncements but also provide the authentic test results and data so our products can be compared with others. In this way, customers will have clarity about our new products and that can only be achieved because we persist in strict standardization.

What level of resources do HYB invest into standardized processes?

Both financial and time resources are a persistently significant investment at HYB. This includes time, technical professionalism, training, machines and testing equipment, and automation tooling to achieve high levels of standardization. We pay for ongoing, third party consultation where all our products and samples are tested, approved and certified to ensure that we meet the appropriate standards.





Gustavo Molinatti

Can Latin America Manufacture its own NBCs—and be Profitable?

Crises have always delivered opportunities for third-party brands, even within the context of a downward trending, or slow-moving economy.

The pandemic of 2020 continues to pose new challenges for the Latino aftermarket which attempts to keep growing, or at least stay profitable with services or by offering new-built (NBC) or remanufactured cartridges.

Crises have always delivered opportunities for third-party brands, even within the context of a downward trending, or slow-moving economy. But unlike other crises which are mainly regional, this one has hit the entire planet without distinction of race and economy. We can expect more countries to close their economies. They will look more carefully at their balance of trade figures. Globalization will be under review, local industries will be encouraged and all “avoidable imports” will be discouraged. Is it possible that compatible cartridges will be considered an “avoidable import?”

A National Cartridge—a Utopia?

The idea of producing a domestically or regionally manufactured, compatible cartridge was developed by some

companies here in Latin America some years ago. However, the massive eruption of cheap Chinese-made NBCs made its financially unviable, uncompetitive. So, nothing more came of it.

However, given everything I have just written and the devaluation of all local currencies against the US dollar, it may be possible the equation has changed. It may now be feasible and profitable. Some positive number could possibly emerge.

Usually a product that needs to be “locally made” may contain 25 percent imported components. The rest of that product, including printer cartridges, includes the cost of labor and supplies that can all be obtained locally. The critical elements that would need to be imported due to their manufacturing complexity are:

- toners;
- OPC drums;
- casing or core; and
- microchips

The toner, drum and chip supplier markets are mature and have a long list of companies, mostly based in Asian countries, that offer quality products at competitive prices. As for the casings or cores, it is a more dispersed market. Although they could be manufactured locally, the cost of non-infringing molds being US\$30,000 to US\$50,000 per matrix and per model makes it unlikely to find investors (let’s also think that each model has at least four matrices). Domestic prices can range from \$1 to \$4 per unit, depending on their quality.

The Key to Added Value

Consider this example: Suppose we want to make a quality wine and we do

not have our own vineyard, but we want to compete with other high-end labels. First, we will buy only the high-quality input—the grapes—that we cannot produce ourselves. After that, anything and everything we wish to add will depend on us: the manufacturing processes, quality control, the winemaker’s hand, the quality of the barrels and, finally, the bottle, labeling and marketing. I know several winemakers who make many of the great prestigious wines in Argentina using this process.

The same goes for a “regionally-made” printer cartridge. Starting with the purchase of quality raw materials (toners, chips, OPCs and casings), you can manufacture a cartridge that is superior in quality and performance to its NBC counterpart from China. At the same time, you are creating local jobs. The added value is in the labor, assembly, quality control, packaging and even the possible certification and traceability of the waste. Having quality cores will allow for remanufacturing over multiple cycles.

If we compare the costs between a “regionally-made” printer cartridge vs. a low-cost NBC, let’s not waste time. The business is unfeasible, even more so in the lowest and most massive lines. But if quality is what we are after, the cartridges that yield 8,000 to 10,000 pages mark the balance point where a “regionally-made” manufacturing becomes commercially interesting. ■

Gustavo Molinatti

RT Global Partner for Latam

Molinatti is based in Buenos Aires, Argentina and is publisher of Guía del Reciclador—the Spanish language magazine first published in 2002 for the Latin American printer cartridge aftermarket. HE has organized more the 20 technical and MPS training events in several countries and is helping RT bring VIP Expo events to Brazil, Argentina, and Perú. Please contact <info@guiadelreciclador.com>

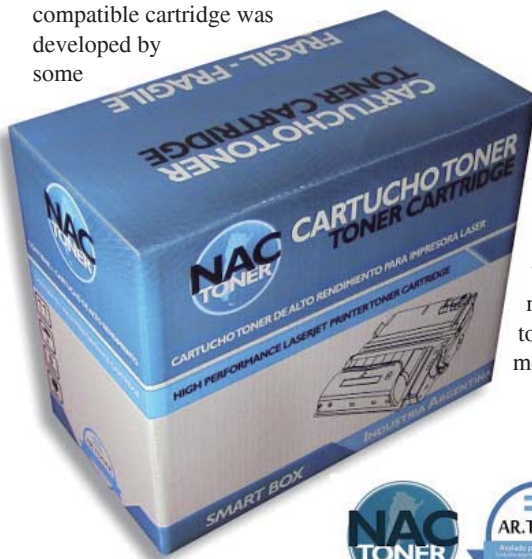

The Argentinian-manufactured "NAC Toner" cartridge promotes the national industry and "high quality standards and performance."



Dhruv Mahajan

India—Price or Standards? Now That is the Question

Until then, the lowest-priced brands “rule the roost” and standards be damned.

India must be the only country in the world to have a full-fledged central government Ministry of Consumer Affairs responsible for ensuring quality standards across all industries and the whole economy. The importance of the Indian Standards Institute can be judged by the fact that it’s been operational since January 6, 1947—even before we gained independence on August 15, 1947.

However, despite the wide acceptance and popularity for quality standards there continues to be product abuse and misuse.

In our aftermarket printing consumables industry, there is one major quality standard all printer manufacturers (including OEMs), importers and national distributors must comply with. It is the dreaded EPR Certification.

India is one of the biggest producers of electronic waste in the world. In 2016, the central government established E-waste (management) rules and highlighted the concept of Extended Producer Responsibility (EPR). It means all manufacturers of electric and electronic equipment—including printers, printer and copier consumables, toner and inkjet ink cartridges—must obtain the EPR from the Central Pollution Control Board (CPCB) in New Delhi and facilitate the collection and return of empty toner and inkjet cartridges to authorized dismantlers or recyclers.

Non-compliance with EPR rules leads to being blacklisted. Not having an EPR Certificate from the CPCB implies you cannot clear customs of any imported products. That is a big worry as 98 percent of



goods are imported with less than 2 percent being manufactured or remanufactured in India.

However, Micro, Small and Medium Enterprises (MSMEs) having revenues of less than Rs 50 million (US\$700,000) per year are exempt from obtaining the EPR. At least half, and possibly two thirds of India’s 4000 importers are classified as MSMEs but they account for only 33 percent of all imports and sales of printer cartridges.

Most Indian consumers (at least 90 percent) of toners and inks are not aware of any standards their vendors, resellers or dealers must comply with before buying products and or MPS services. They choose a supplier who can offer them the best deal. The most important mantra or criteria in India is to buy from somebody or anybody who can offer the lowest price for each SKU.

Leading vendors and manufacturers have for years tried to explain to their buyers the advantages of buying products having relevant ISO certificates for the cartridges and for manufacturing facilities to ensure quality compliance, product performance and environmental sustainability but with limited success. ISO 9000 and ISO 14000, ISO/

IEC 19752 (printer cartridge yield for monochrome prints) and ISO/IEC 19798 (color printer cartridge yield), STMC, REACH, RoHS, Blue Angel, Nordic Swan or CE compliance mean very little to more than 95 percent of buyers and end users.

Shamelessly, most import aftermarket compatible toner and inkjet cartridges from Chinese manufacturers in their own branded cartons

with all the possible certificates printed on the side of the cartons. Industry experts and vendors are unable to prove non-compliance by the Chinese supplier, exporter or Chinese factory producing the toner or inkjet cartridges. Making that search easy and credible will help in eventually making some standards and certificates meaningful.

Until then, the lowest-priced brands “rule the roost” and standards be damned. The high-quality genuine manufacturers, their importers and distributors continue to suffer low volume sales and success comes after great effort and a very strong, long-standing relationship between the supplier and the buyer. In most cases both have effectively become partners rather than just buyer-seller relationships. Sadly, such loyalty does not widely prevail in our industry in India. ■

Dhruv Mahajan

RTGlobal
Partner
for India

Mahajan is based in New Delhi as the International Business Development Manager for Fast Image Products responsible for the Gulf and South-east Asia regions. Mahajan is partnering with RT to bring VIP Expo one day intensive events to three cities in India each year. Please contact him at <dhruvm@zhfast.com>



Mark Dawson

Printer Supplies Opportunities Post COVID-19

While the OEMs try to turn their oil tankers, our industry speedboats have shown how nimble and versatile we can be.

Very rarely does one global event come along and change the landscape. In our lifetime, we have seen regional conflicts, acts of terror, natural disasters, and trade wars which impact some industries, in some geographies, some of the time. Like the 2008 financial crash, this current pandemic crisis is global but is having a deeper impact upon our daily lives. At the time of writing, more than 320,000 have died. Societies and economies all over the world have been shut down.

What does it mean for those of us that depend upon printer supplies to make a living? In short term, it has crashed the toner cartridge business. But, change always brings opportunity. As Jimmy Dean famously said, "We cannot change the direction of the wind, but we can adjust our sails to reach our destination." The speed at which many players have switched focus is a source of pride. Inkjet, 3D printer filaments and PPE are booming. While the OEMs try to turn their oil tankers, our industry speedboats have shown how nimble and versatile we can be.

We cannot be like the ostrich that bury its head in the sand. The longer-term impact of this crisis will also deliver new opportunities. On the one hand, we need to recognize it will amplify and accelerate certain pre-existing trends. One of those is a reduction in global page volumes. During the crisis, some remote workers have used inkjet and smaller footprint laser for their hard copies. But others have learned to live without hard copies and will bring their new habits back to the office. On the other hand, we must not forget that our industry



was born out of the concept of reuse and has always thrived in recessionary times.

We have observed the decline in emissions caused by COVID-19 which shows the impact of reduced human activity. Clearly, we must get the wheels of the global economy turning again as soon as it is safe to do so. This is essential for wealth creation and distribution to improve the lives of everybody. It does not mean we should allow old habits to return and so follow the previous trajectory.

Some things will never be the same. We must harness this increased acceptance of change to accelerate the decoupling of economic growth from the consumption of our finite resources. Designing out waste and pollution, prolonging useable lifecycles, and regenerating natural systems should be our focus. These are the pillars of a circular economy.

Our remanufacturers are in pole position to take advantage. We must think of remanufacturing in a wider scope and fully embrace hardware as well as supplies. OEMs will be under more pressure than ever to place new devices. The pushback will come from corporations that will not commit to expensive leases due to economic

uncertainty. Such enterprises will demand lower cost solutions.

Delivering lower cost is in our DNA. Hardware is out there for us to refurbish. In both the transactional and Platform-as-a-Service (PaaS) models, we have the edge over OEMs. We prolong lifecycles and keep products and materials in use for longer. And we drive cost reduction.

Post COVID-19, the transactional business model will catch a second wind. In parallel, those corporations that do seek a subscription model will be ripe for one based around remanufactured devices and supplies. The refurbished MFP market will accelerate. By offering bundled hardware and supplies we can capture more revenue and more margin.

For the first time, we even see the emergence of new build compatible cartridges that are designed to be remanufactured! If we are as successful as I think we can be, we may not be able to rely on OEM empty cartridge availability. Could this be a development that eventually brings together the two tribes, reman versus NBC? An acceleration of industry consolidation is inevitable anyway. It might force that coming together. ■

Mark Dawson

RT Global
Partner
for EMEA

Dawson joined the imaging supplies industry in 1987 and has held senior positions with both American and European corporations, including MSE and Clover. He is a director with Internet of Printing BV helping independent resellers find new revenue streams and to optimize margins. Dawson is partnering with RT to bring VIP Expo one day intensive events to the UK, France and the Netherlands. Please contact <mark@iopbv.com>



Marketplace



SUNWISE
Think Tank

Peripherals & Consumable & IT Market Research
Japan/China/India/Korea/Russia/Brazil Market
TEL: +81-453172818 FAX: +81-453172817
Email: kanetoyo@sunwise2001.com
website: www.e-sunwise.com
Chuo 1-29-16-301, Nishi-ku, Yokohama, JAPAN
Our Indian Market Research Partner



BUSINESS ANALYST GROUP

Ph: +91-3324252469 Cell: +91-9831177399
Email: ruchira.mukherjee@businessanalyst.in
website: www.businessanalyst.in
South Santoshpur, Ghoshpara, Jadavpur,
Kolkata - 700 032, West Bengal, INDIA



PARTS OVERNIGHT
NEW ZEALAND

Proudly supplying KIWI resellers for 16 years

WHOLESALE DISTRIBUTOR -

- ⇒ Printer Parts
- ⇒ Ink and Toner cartridges
- ⇒ Bulk Toner — Universal Toners for Brother, HP, OKI and Kyocera
- ⇒ Remanufacturing supplies and accessories

Email: sales@partsovernight.co.nz
Tel: +643794051
www.parsovernight.co.nz



Quality Assurance = Disaster Avoidance

Choose Leak-Free Katun® Printer Toner Cartridges

KATUN®

Looking forward to Expand your Industry network?

ECTEC™
Egypt China Technology and Exhibitions Center
埃中科技展览中心
Your Success Partner

Planing, Marketing, Construction, Managing

YOUR VISION... OUR INNOVATION... BEST EVENT SOLUTIONS.

Contact Us:
2 Fawzi st., First of Terat Al-Gabal,
Saray Al-Quppa, Cairo, Egypt
(+20100) 6394323 - (+2010) 11880164
info@egyptchinatec.com EgyptChinaTEC
www.egyptchinatec.com ECTEC.Egypt

CMYK INDUSTRIES

- Recycling Supplies
- Compatible Printer Cartridges
- Digital Label Printers
- Consult

www.cmykindustries.co.za



Unismart 3
TOUCH A BETTER RESET SOLUTION



Reduce your inventory!
Fast, European delivery!
First to offer new models!

Be Smart, buy your Unismart3 today!

TOKO, APEX East European Partner
www.ecoChips.eu sales@ecochips.eu



RT NEWS RecyclingTimes
Your Global Media Partner

WE'VE RESERVED A SEAT FOR YOU TO HELP YOUR BUSINESS GROW



For magazine advertising, please contact:
Victoria Zhao
Tel: +86-756-3919263
Email: Victoria.Zhao@RTMworld.com
www.RTMWorld.com

ADVANCED
CONSUMABLE TECHNOLOGIES

IMAGING EXPERTS
Australian distributor of consumables

www.adcon.net.au

BADGER
OFFICE SUPPLIES

**TRADE DISTRIBUTOR
OF PRINTER
CONSUMABLES**

- 18,000 product lines
- Huge stock availability
- Drop-ship service
- International dispatch

email: sales@badgeroffice.co.uk
tel: +44 (0) 1772 299 029
www.badgeroffice.co.uk

Coastal Inkjets

Toll Free: 866-410-9600
Int: 818-534-2316
Fax: 818-534-2319
Email: coastalinkjets@gmail.com

**All Types of Empty
Cartridges available
for sale. Virgin or
Nonvirgin. Laser and
Inkjet available.**

Empties - the
lifblood of
our industry

**We make
buying and
selling empties
simple.**

Always buying,
Always selling,
Always here!

Europe's Largest Dealer of Empty Cartridges
Over 600,000 empties in stock

UK and International Tel: +44(0)1908 635330 Fax: +44(0)118 943 9001 Email: Llerwill@itp-group.com Web Site: www.itp-empties.com	Germany Tel: +49(0)6182 958880 Fax: +49(0)6182 9588877 Email: Njursch@itp-group.com Web Site: www.itp-empties.com
---	--

FAV Group of Companies
one of the major importer of

**PHOTOCOPIER TONERS
PRINTER TONERS
CONSUMABLES**

Deals in all type of toners, toner products
consumables used in photocopiers
printers & multifunction products irrespective
of the brands & models

info@vawda.com
+92 (21) 255 0093-98
Head Office: B-66/A, SITE Area,
Karachi-75700, Pakistan

China Stationery Fair
—RemaxWorld Shanghai 2020
September 17-19
Shanghai · China

RemaxWorld Expo 2020
October 15-17
Zhuhai · China

iPrint Expo 2020
October 15-17
Zhuhai · China

www.RTMworld.com

**WE CAN HELP YOU TO
COMMUNICATE WITH THE WORLD**

	ID: recyclingtimes 20,000+ followers		ID: Recycling_Times 18,000+ followers
	ID: RT Media Co., Ltd. 8,000+ followers		ID: Intouchnews 67,000+ video views
	ID: Recycling Times Media 22,000+ video views		Chinese Toutiao App 76,000+ annual page views
	WeChat ID: i3dpworld 57,000+ followers		WeChat ID: irecyclingtimes 17,000+ followers

RT www.RTMworld.com

DID YOU KNOW?



If you leave your printer on all day, the firmware may be updated in 10 to 30 minutes without you even knowing, as most printers' default settings are automatically updated.

Source: <https://bit.ly/3gaNbiv>

TECH-ZONE

Remanufacturing the HP Color LaserJet Enterprise M751 series Black and Color Toner cartridges

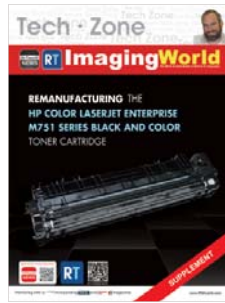

RT's Cartridge Library



ADVERTISERS

Company Names	Pages
Advanced	55
Asay	38
Badger	55
Business Inform	16
CET Group Co., Ltd	2
CMYK	54
Coastal Inkjets	55
ECTEC	54
FAV	55
Future Graphics	Back
I-ITC	22
Katun E.D.C	54
KILIDER	4
Parts Overnight	54
Sunwise	54
Toko	54
UniNet	18
Zhono	10

COMING EVENTS

RT Business-inform 2020
June 3-5, Russia
**Postponed to 2021*

RT RemaxWorld Expo 2020
iPrint Expo 2020
October 15-17, Zhuhai · China

RT RT Imaging VIP Expos—Americas 2020
July 3 / 6 / 9, Argentina / Brazil / Peru
**Postponed to 2021*

RT RT Imaging VIP Expos—Africa 2020
November 16 / 19 / 23, Ethiopia / Algeria / Nigeria

RT China Stationery Fair
—RemaxWorld Shanghai 2020
September 17-19, Shanghai · China

For further details, view at www.RTMworld.com

BERTO'S LAST LAUGH



USPS ID STATEMENT

RT Imaging World, ISSN 2632-6728, is published monthly by Recycling Times Media Corporation (Seameadow House, Blackburne Highway, PO Box 116, Road Town Tortola, British Virgin Islands).

The annual subscription price for hardcopy is US\$55.

The US annual subscription price is US\$55. Airfreight and mailing in the USA by agent named WN Shipping USA, 156-15, 146th Avenue, 2nd Floor, Jamaica, NY 11434, USA.

Periodicals postage paid at Jamaica NY 11431. US Postmaster: Send address changes to RT Media Co., Ltd, WN Shipping USA, 156-15, 146th Avenue, 2nd Floor, Jamaica, NY 11434, USA

Subscription records are maintained at Recycling Times Media Corporation (Seameadow House, Blackburne Highway, PO Box 116, Road Town Tortola, British Virgin Islands).

Air Business Ltd is acting as our mailing agent.



OCTOBER 15-17 2020 SAVE THE DATE! RemaxWorld Expo 2020

Please scan the QR code
or visit bit.ly/rwem20
to get your tickets.



I've got
perfect 20/20
vision for 2020!



To visit, please contact:

Kim Tan

☎ +86-756-3959285

✉ Kim.Tan@RTMworld.com

To exhibit, please contact:

Victoria Zhao

☎ +86-756-3919263

✉ Victoria.Zhao@RTMworld.com

www.RTMworld.com



The Right
CHEMISTRY



REMANUFACTURE

with Matching Gear, OPC and Toner, DIRECT from ONE MANUFACTURER



FUTURE GRAPHICS >



FOR FURTHER INFORMATION CONTACT CUSTOMER SERVICE TODAY

Sales: 1 (818) 837-8100 | **Tech Support:** 1 (800) 466-0246 | **Email:** info@fgimaging.com | **Website:** www.fgimaging.com